



www.santos.fr

**COLD PRESS JUICER #65**  
*The solution to all your juicing needs!*

**NEW!**

**Slow extraction**

**XL Chute**

**Extreme reliability**



Internationally patented models™





## COLD PRESS JUICER #65



### AN INNOVATIVE COLD PRESS JUICER

Thanks to its patented slow juicing system, the Cold Press Juicer #65 is the first counter-top commercial cold press juicer, that can be used continuously, in front of the customers. The slow extraction of juice preserves the nutrients, enzymes, vitamins and minerals naturally present in fruits, veggies and leafy greens. Perfect to make detox juices on-demand, especially green juices with kale, spinach, celery...

### SANTOS COLD PRESS TECHNOLOGY

www.santos.fr

**Extra wide chute**  
Ø79.5mm.  
Fits whole fruits and vegetables

**Exclusive patented slow juicing system**

**High spout**  
accepts glasses, jugs and blenders jars  
height: 21 cm

**Pulp container**  
4 litres

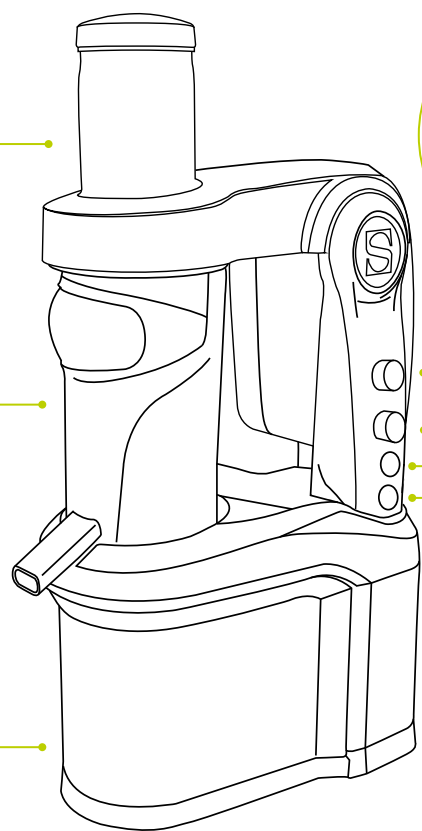

**Variable speed**  
Personalize your juice :  
simply set your speed and filtration size to get the juice you want

**On/Off Button**  
Reverse

NUTRITION

SLOW JUICING

RAW JUICE



#### Patented juicing system

Exclusive technology developed and patented by Santos.  
Slow extraction of juice :  
—  
Preserving vitamins, nutrients, enzymes and minerals,  
—  
Minimizing juice separation and oxydation  
—  
Maximum juice extraction



#### Commercial induction motor

Extremely reliable and long lasting  
—  
Silent  
—  
Allowing variable speed to juice any type of fruits, veggies, herbs...



#### XL Chute

Wide chute Ø79.5mm to juice whole fruits and vegetables  
—  
No pre-cutting needed

#### TECHNICAL SPECIFICATIONS



**Motor**  
220-240 V – 50/60 Hz – 650 W  
100-120 V – 50/60 Hz – 650 W  
  
Speed : 5 to 80 rpm



**Weight**  
Net : 31 kg (68.3 lbs)  
Shipping : 34 kg (74.9 lbs)

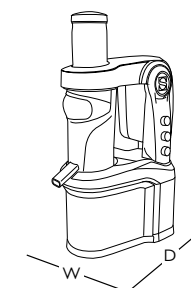

**APPLIANCE**  
D : 412 mm (16.2")  
W : 233 mm (9.2")  
H : 640 mm (25.2")

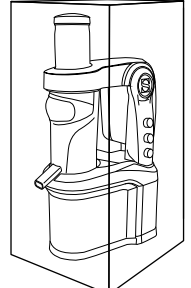

**SHIPPING BOX**  
D : 490 mm (19.3")  
W : 330 mm (13")  
H : 660 mm (26")

### WHAT ARE THE BENEFITS OF SANTOS COLD PRESS JUICER #65 ?



#### 1 Commercial appliance

Aluminum body and stainless steel foodzone. Equipped with a reliable induction motor.

#### 2 A new way of juicing

Set your speed and your filtration size.

#### 3 Excellent yield

Extracts the maximum juice.

#### 4 Fresh and pure juice

Cold pressed juice retains a maximum amount of nutrients, enzymes, minerals and vitamins.

#### 5 Easy to use and to clean

Extra wide chute. All the parts in contact with food are removable.

#### SAFETY, STANDARDS, HYGIENE

##### In accordance with the following regulations

Machinery directive 2006/42/EC  
Electromagnetic compatibility 2014/30/EU  
Electrical equipment designed for use within certain voltage limits "low voltage" 2006/95/EC  
Regulation 1935/2004/EC (contact with food)  
RoHS directive 2011/65/EU  
Directive DEEE 2012/19/EU

##### Harmonized European Standards

EN ISO 12100 - 1 and 2:2010  
EN 60204-1+A1 :2009  
EN 60335-2-64 :2004 Commercial electric kitchen machines  
CE marking

##### Thermal Safety

Motors protected by thermal detector and overload protector

##### Electrical safety

All mechanical parts are ground connected  
Appliances are 100% tested after assembly

##### Acoustic Safety

Silent asynchronous motor

##### Hygiene

All removable parts can be put in a dishwasher or easily cleaned with hot soapy water

PRODUCT : 2-YEAR WARRANTY | MOTOR : 5-YEAR WARRANTY

# COLD PRESS JUICER #65



www.santos.fr

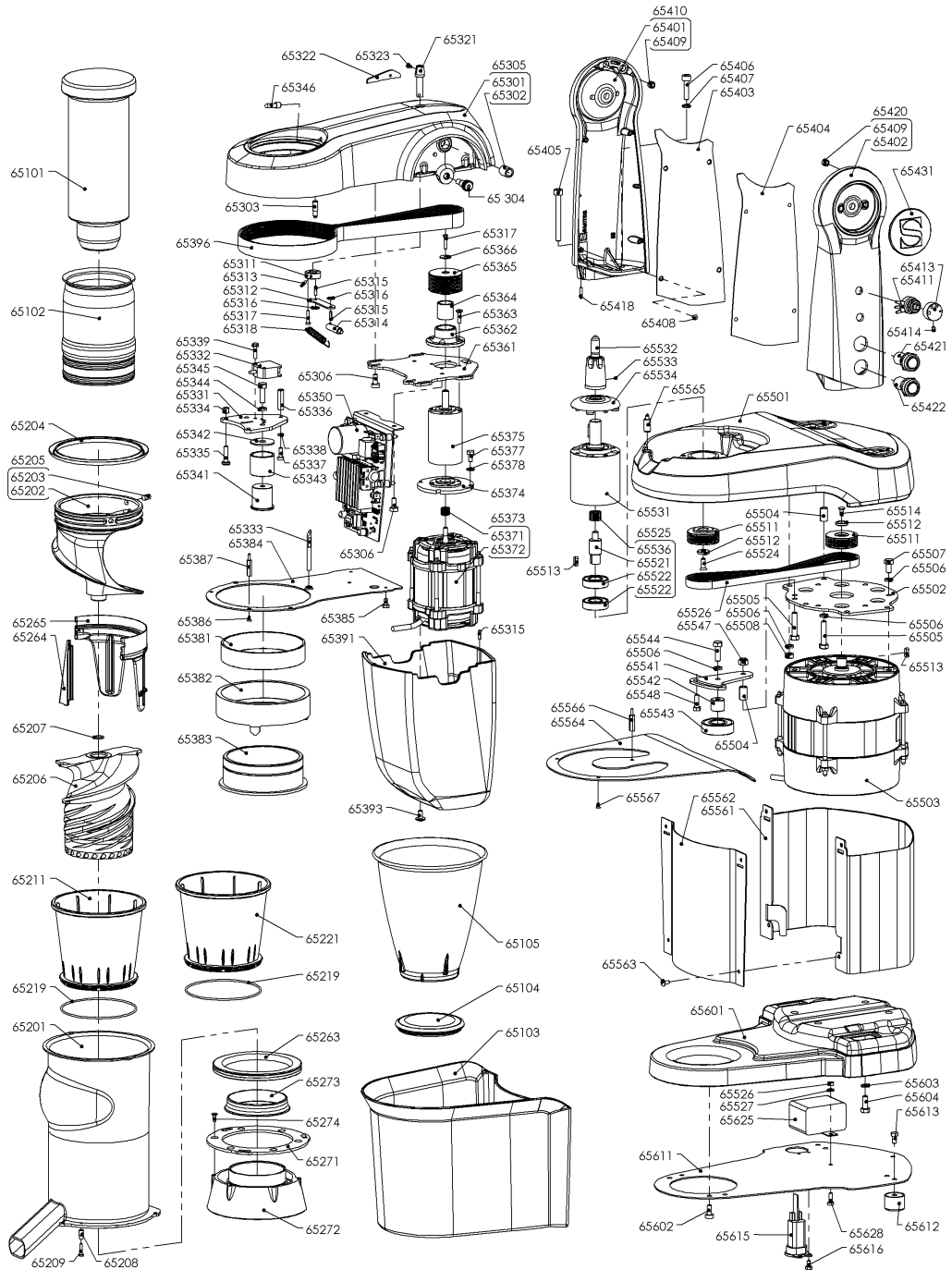

**SANTOS**

140-150, avenue Roger Salengro BP 80 067 - 69511 Vaulx-en-Velin Cedex (Lyon) FRANCE – Tel. +33 4 72 37 35 29 – Fax. +33 4 78 26 58 21

**Website :** www.santos.fr – **Email :** santos@santos.fr