

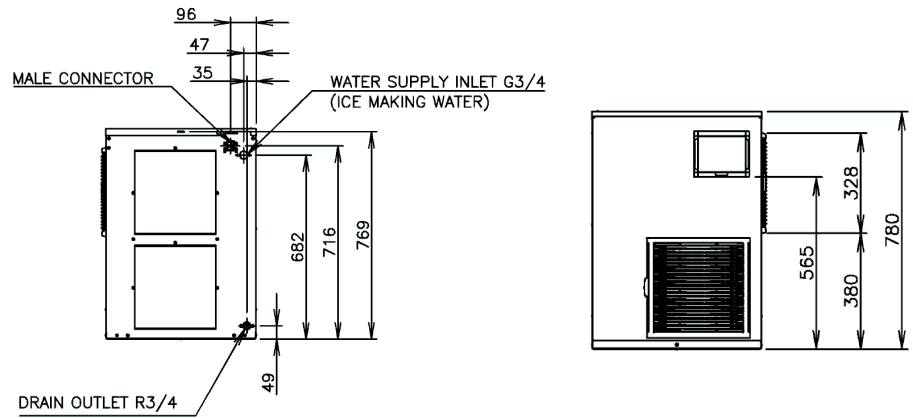

### PRODUCT FEATURES

- "Freeze Burn" is no longer an issue when displaying fresh fish or produce.
- Carbon auger bearings have a longer life expectancy than roller bearing, reducing maintenance costs.
- Automatic flush function, helps keep the ice making system clean.
- Controller board with Operational Status display assists in trouble shooting.
- Due to the auger system, water consumption is equal to ice production.
- 2 year parts & labour on entire unit, 5 year (parts only) on compressor & air cooled condenser coil.

### TECHNICAL DRAWING

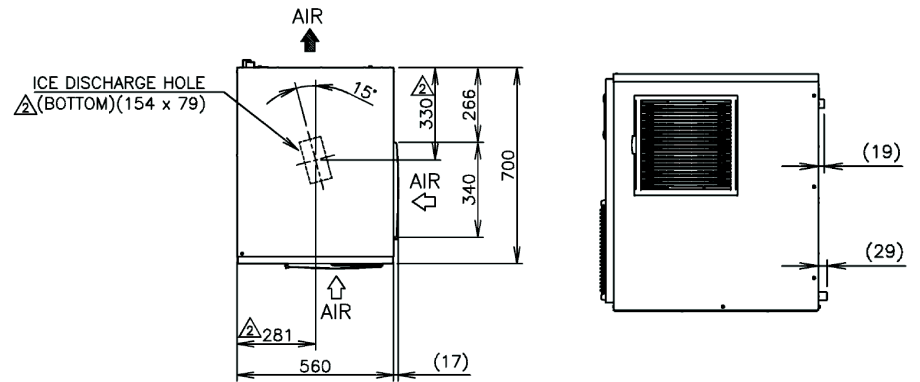

SHAPE OF ICE:



### PRODUCT SPECIFICATION

Production Capacity per 24hours	Approx. 430kg @10°C Air temp; 10°C Water Approx. 360kg @ 21°C Air temp; 15°C Water Approx. 290kg @ 32°C Air temp; 21°C Water
Max Storage Capacity	Select Bin & Kit
Dimensions	560mm (W) x 700mm (D) x 780mm (H)
Cooling	Air
Weight Net/Gross (kg)	95 / 102
AC Supply Voltage	1 PHASE 230V 50Hz /10AMP Plug
Amperage	Running: 8.4A Starting: 43A
Refrigerant Charge	R404A
Operating Conditions	Ambient Temp.: 5-40°C Water Supply Temp.: 5-35°C Water Supply Pressure: 0.07-0.8MPa (0.7-8bar) Voltage Range: Rated Voltage ±10%



Descriptions and specifications are subject to change at any time, without notice. Illustrations for demonstration purposes.

Copyright © 2020 Hoshizaki Lancer Pty Ltd. All right reserved. E&OE Date: Sept 2020