



BIN200-P

ICE STORAGE BIN

Stainless steel storage bin which sits underneath a range of Brema modular ice machine heads.

The BIN200-P stores 200kg of ice and has an insulated polyethylene moulded tank and door to ensure long-lasting, quality ice.

When coupled with an ice cube or ice flake head, the BIN200 generously stores ice to meet peak demand times for a range of applications.

Can be coupled with: C150, VM350/500/900, TM250/450, G160/280/510.

STANDARD FEATURES

- 200kg storage capacity
- Can be coupled with a range of Brema modular ice machine heads
- Stainless steel 18/8 construction
- Polyethylene moulded tank and door for insulation

STANDARD ACCESSORIES

- Drainage hose
- Adjustable stainless steel legs (4)
- Plastic ice scoop

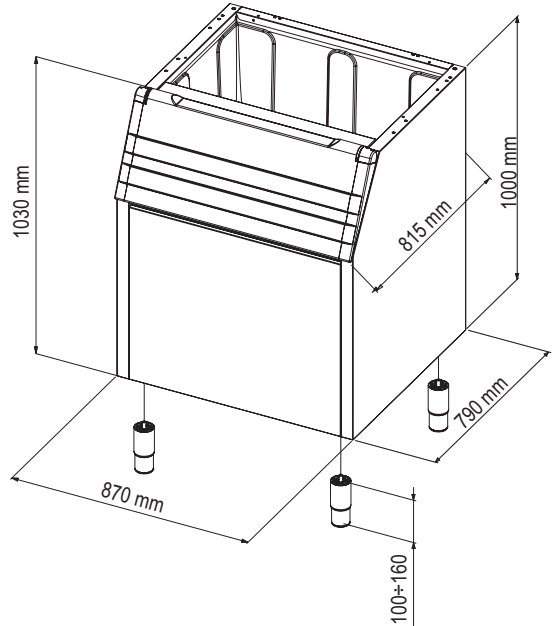

DIMENSIONS

870W x 815D x 1030*H mm *(add 100-160mm for adjustable legs)

Clearances: Rear: 100mm Sides: 100mm

CONNECTIONS

24mm Water outlet

TECHNICAL DATA

Storage Capacity: 200kg
Weight: 74kg

USABLE WITH MODULAR HEADS

C150, VM350/500/900, TM250/450, G160/280/510

SPECIFICATIONS ARE SUBJECT TO CHANGE WITHOUT NOTICE.



National Head Office
156 Swann Drive
Derrimut VIC 3030
Tel: +61 3 8369 4600
Fax: +61 3 8369 4699
www.comcater.com.au

Melbourne
96-100 Tope Street
South Melbourne VIC 3205
Tel: +61 3 8369 4600
Fax: +61 3 8699 1299

Sydney
20/4 Avenue of the Americas
Newington, NSW 2127
Tel: +61 2 9748 3000
Fax: +61 2 9648 4762

Brisbane
40-60 Dunhill Crescent
Morningside QLD 4170
Tel: +61 7 3900 2700

Perth
Unit 16, 7 Abrams Street
Balcatta, WA 6021
Tel: +61 8 6217 0700
Fax: +61 8 6217 0799