

## PRODUCT CATALOGUE



## Designed to Perform ~ Built to Last!



*We are proud to present our range of quality, stylish and high-performance commercial food service equipment.*



An icon of the Australian food service industry, the Roband name is instantly associated with *quality, innovation, reliability and service*. This reputation, coupled with our strong history, is your *guarantee of a quality product* that is backed by a strong, customer focused organisation.

All Roband and Austheat products are manufactured in Australia with national and international distribution to over twenty countries.

Roband Australia is also pleased to present the range of *Robatherm* microwaves, hot water urns and a percolator, manufactured overseas to our exacting standards and backed by *Roband's service warranty*.



Roband is delighted to play our part in the official *Australian Made campaign*.

A wide range of equipment now carries the official "Austalian Made" logo from Roband branded benchtop equipment to grillstations, milkshake mixers as well as the Austheat range of floor standing electric fryers.

All backed with industry leading *warranty, parts and service*.

## Contents

### 4-5 **Drinks**

- 4-5 Milkshake & Drink Mixers

### 6-13 **Grilling/Toasting**

- 6-10 Contact Grill Stations
- 11 Grill Max Wide-Mouth Toaster
- 12 Grill Max Toasters - Stainless Element
- 13 Grill Max Toasters - Glass Element

### 14-17 **Frying**

- 14-15 Frypods
- 16-17 F Series
- 17 Donut

### 18-23 **AUSTHEAT**

- 18-21 Freestanding Electric Fryers
- 22-23 Freestanding Hotplate/Grill

### 24-29 **Toasting**

- 24 Conveyor Toasters
- 25 Eclipse Bun & Snack Toasters
- 26-28 Sycloid® Toasters
- 29 Vertical Toasters
- 29 Salamander

### 30-33 **Griddle - Toasting**

- 30-31 Griddles
- 32-33 Griddle Toasters

### 34-39 **Warmers & Cookers**

- 34 Pie Master Pie & Food Warmers
- 35 Hammertone Finish Pie Warmers
- 36 Multi-Function Chip & Food Warmer
- 37 Chip Warmer
- 38 Boiling Hot Plates
- 38 Coffee Warmer
- 39 Pasta Master/Vegetable Blancher
- 39 Hot Dog & Bun Warmers

### 40-43 **Bain Maries**

- 40-41 Counter Top
- 42 Sauce Warmer
- 42 Chocolate Bain Maries
- 43 Hot
- 43 Refrigerated

### 44-52 **Food Display Bars & Accessories**

- 44 Straight Glass Hot
- 44 ~ Single Row
- 44 ~ Double Row
- 45 Straight Glass Refrigerated
- 46 Curved Glass Hot
- 47 Curved Glass Refrigerated
- 48 Square Glass Hot
- 49 Square Glass Refrigerated
- 50-52 Accessories/Pan Layout Guide

### 53-59 **Heating/Lighting**

- 53 Modular Heat Lamp
- 53 Individual Heat Lamps
- 54-55 Quartz Heat Lamp Assemblies
- 56-57 Infra-Red Heating Assemblies
- 58 Fluorescent Lighting Assemblies
- 58 Optional Mount Kit
- 59 Heat Lamp Stands

### 60-61 **ROBATHERM**

- 60 Hot Water Urns
- 61 Percolator

### 62-63 **Operations/Warranty**

- 62 Operating Specifications & Disclaimers
- 63 Warranty Information

## Milkshake & Drink Mixers



### DM31 Milkshake and Drink Mixer:

*"Sealed Design" for easier cleaning & better hygiene ~ Versatile beater combination ~ Smaller footprint*

Roband milkshake mixers are the ideal machine for making perfect thickshakes or milkshakes every time. The Saturn beater produces extra fluffy shakes using minimal ingredients, time after time. The Universal Beater is stainless steel & has 2 blade options ideal for making normal milkshakes through to thickshakes. Merging style, power & performance these mixers are a must for cafes & fast food outlets.

### FEATURES

#### Operation

- The Saturn beater for extra fluffy shakes is included
- Separate internally sealed two-speed on/off rocker switch
- High performance stainless steel mixing spindle
- Takes standard 710 ml (24 fl.oz.) cups without tilting to remove
- Includes stainless steel cup
- 'Hands free' operation when the mixing cup is resting on the cup support
- Available in red, white, black, seaspray & metallic

#### Performance

- Powerful two-speed motor, 18,000 RPM on low and 22,000 RPM on high speed
- High performance stainless steel beater for use with ice cream and milk

#### Cleaning/hygiene

- Patented magnetic actuator, fully sealed for optimum hygiene
- Removable easy to clean cup holder
- Sturdy weighted base, easy to clean



## SPECIFICATIONS

MODEL	COLOUR	POWER Watts	CURRENT Amps
DM31W	White	150	0.7
DM31B	Black	150	0.7
DM31R	Red	150	0.7
DM31S	Seaspray	150	0.7
DM31M	Metallic	150	0.7

## DIMENSIONS

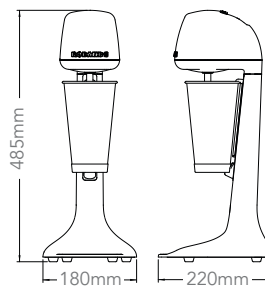

## FEATURES & BEATER OPTIONS

Universal Beater - lower disc only for creamy milkshakes

Universal Beater - using both discs for thickshakes, ice cream & soft serve

Saturn Beater - for extra fluffy shakes

Separate internally sealed two-speed on/off switch

Easy-clean weighted base for cleaning spillage



## Contact Grill Stations

The modern, stylish Roband Grill Station is available *in six or eight slice size models*. The Roband range sets the benchmark for commercial contact grills. *The versatile unit* rapidly toasts sandwiches, paninis and focaccias, in addition to producing beautifully seared and grilled tender meat, poultry and fish. Featuring elements embedded directly into smooth, high pressure die-cast aluminium plates, the cooking surface produces an even, extremely efficient heat transfer ensuring food is cooked rapidly with even colouration for enhanced appetite appeal.

The Roband Grill Station truly is a must-have for cafes, takeaways, sandwich shops or anywhere that toasting and / or grilling is required.



### FEATURES

#### Cooking

- Six or eight sandwich capacity
- Quality high pressure die-cast aluminium cooking plates with cast-in elements for efficient, directional and effective heat transfer
- Even temperature distribution across each plate and between the top and bottom plates
- Precise thermostat for controlling cooking temperature
- Includes one premium Spatula

#### Operation

- Ability to switch between top and bottom plate operation or bottom plate only operation
- A counter-balanced top plate and an arched handle makes operating the Grill Station easy
- Easy one-handed loading and unloading of food while the top plate stays open half way
- Food quality & appearance is protected from over compression by the counter balanced and self levelling top plate
- Small counter space requirement due to the elimination of a cumbersome back cable
- Angled control panel for clear visibility of settings

#### Timers

- 5 minute Manual Timer with warning bell
- Electronic Timer models **8 timer capability** - 4 individual timers, each with two pre-set time periods, up to 10 minutes

#### Cleaning / Maintenance

- High splash guard with top plate always positioned over bottom plate ensuring grease and crumbs fall onto bottom plate
- A front positioned grease collection box collects grease and crumbs and is well-positioned for easy removal and cleaning

#### Optional accessories:

- Ribbed top plate and / or non-stick coating (For manual timers only)
- Non-stick Roband Grill Sheet & Retainer Clip keeps the plates clean, prevents food sticking and is removable, cleanable & replaceable
- Plate spacers are available separately for delicate items
- Side draining grease channel for high volume waste (model GC6 or GC8 and for manual timers only)



## FEATURES & OPTIONS FOR ALL GRILL STATIONS WITH MANUAL OR ELECTRONIC TIMERS

Top plate props open for easy access to food

Food quality and appearance is protected from over compression by the counter balanced and self levelling top plate

Plate options



Top plate always positioned over bottom plate. Smooth or ribbed\* top plate options available. (\*Only available for Manual timer models.)

High splash guard

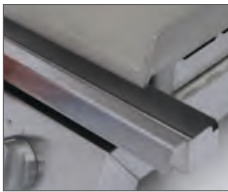

Removable grease tray

Top & bottom or bottom only plate selection



No cumbersome back cable, reducing counter space required

Thermostat control

Manual Timer

GSA610S pictured

Smooth plate  
Teflon® coated\*

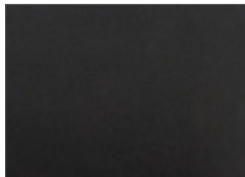

Ribbed top plate  
Teflon® coated\*

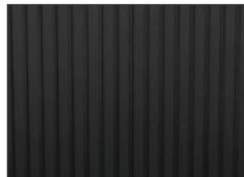

Smooth plate

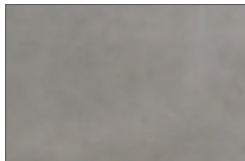

Sample from ribbed top plate\*



(\*Only available for Manual timer models.)



GSA610SE pictured

Electronic Timer 8 timer capability (4 individual timers, each with two pre-set time periods (up to 10 minutes))



## Grill Stations cont'd

### SPECIFICATIONS

MODEL	SLICES No.	TIMER	PLATE COATING	TOP PLATE	POWER Watts	CURRENT Amps	DIMENSIONS w x d x h (mm)	BOTTOM PLATE DIMENSIONS w x d (mm)
GSA610S	6	MANUAL	NIL	SMOOTH	2200	9.6	435 x 490 x 228	375 x 275
GSA610R	6	MANUAL	NIL	RIBBED	2200	9.6	435 x 490 x 228	375 x 275
GSA610ST	6	MANUAL	NON-STICK	SMOOTH	2200	9.6	435 x 490 x 228	375 x 275
GSA610RT	6	MANUAL	NON-STICK	RIBBED	2200	9.6	435 x 490 x 228	375 x 275
GSA610SE	6	ELECTRONIC	NIL	SMOOTH	2200	9.6	435 x 490 x 248	375 x 275
GSA810S	8	MANUAL	NIL	SMOOTH	2300	10.0	560 x 490 x 228	500 x 275
GSA810R	8	MANUAL	NIL	RIBBED	2300	10.0	560 x 490 x 228	500 x 275
GSA810ST	8	MANUAL	NON-STICK	SMOOTH	2300	10.0	560 x 490 x 228	500 x 275
GSA810RT	8	MANUAL	NON-STICK	RIBBED	2300	10.0	560 x 490 x 228	500 x 275
GSA810SE	8	ELECTRONIC	NIL	SMOOTH	2300	10.0	560 x 490 x 248	500 x 275
GSA815S	8	MANUAL	NIL	SMOOTH	2990	13.0	560 x 490 x 228	500 x 275
GSA815R	8	MANUAL	NIL	RIBBED	2990	13.0	560 x 490 x 228	500 x 275
GSA815ST	8	MANUAL	NON-STICK	SMOOTH	2990	13.0	560 x 490 x 228	500 x 275
GSA815RT	8	MANUAL	NON-STICK	RIBBED	2990	13.0	560 x 490 x 228	500 x 275
GSA815SE	8	ELECTRONIC	NIL	SMOOTH	2990	13.0	560 x 490 x 248	500 x 275

Note: All bottom plates are smooth. Timer does not over-ride or control thermostat.

### DIMENSIONS - ALL MODELS

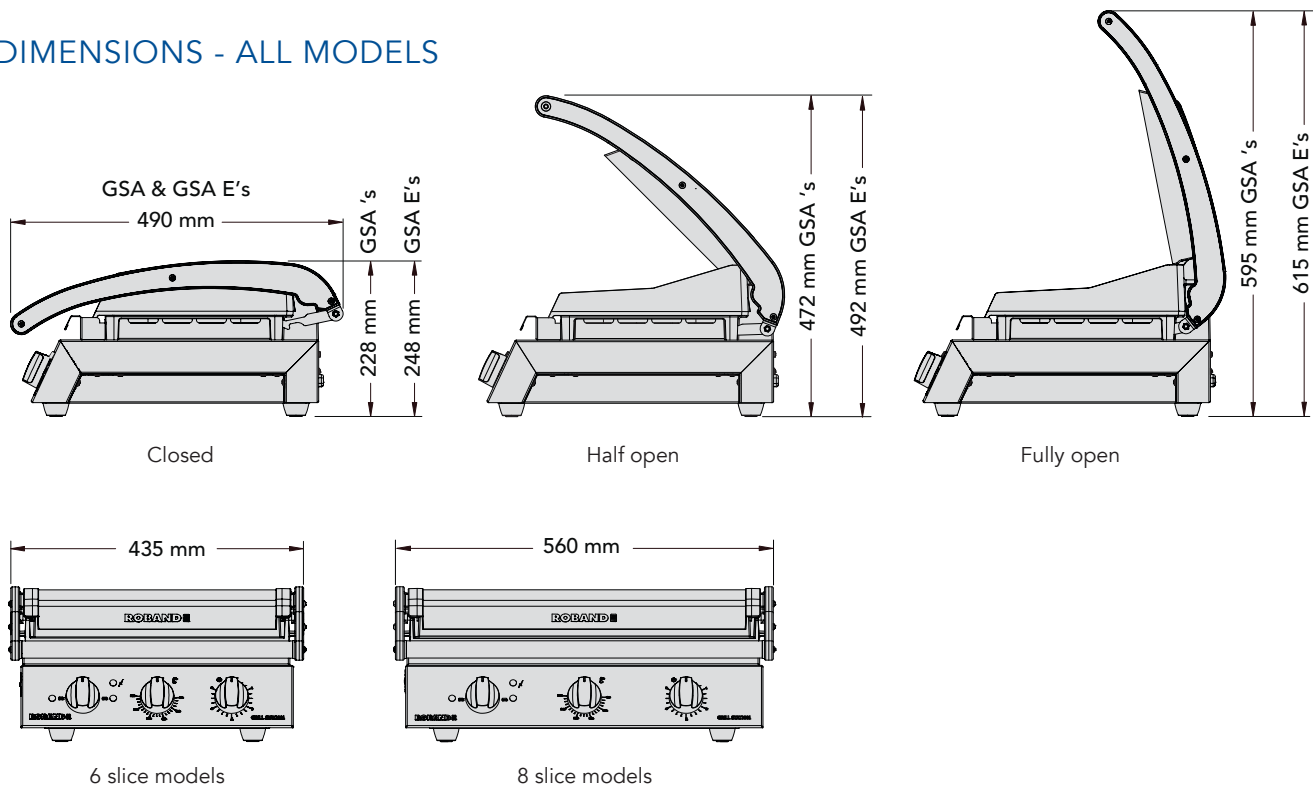



## FEATURES & OPTIONS FOR ALL GRILL STATIONS

### Retainer Clip & Grill Sheet

these are used to keep the Grill Station plates clean during use. They are easily removed for washing. The sheet is also non-stick preventing the food from sticking to the plates. Ideal for high productivity and fast cleaning.

### Side Draining Grease Channel

this is designed to handle high volume of grease from cooked food. The Grease Channel drains into a collection vessel such as a small steam table pan. (\*Only available for Manual timer models).

### Rear Stand

the Rear Stand is designed to raise the Grill Station rear so that grease and crumbs drain & collect in the forward positioned grease box.

### Plate Spacer

various sizes are available and these are designed to ensure a consistent height is maintained between the top and bottom plates during operation. These are ideally suited to preparation of delicate products such as croissants.

### Aluminium Grill Pattern Plates

Designed to sit between the Grill Station smooth plates and Grill Sheet with Clip, the Aluminium Grill Pattern Plates produce a crosshatched char grill style pattern on the food being produced.

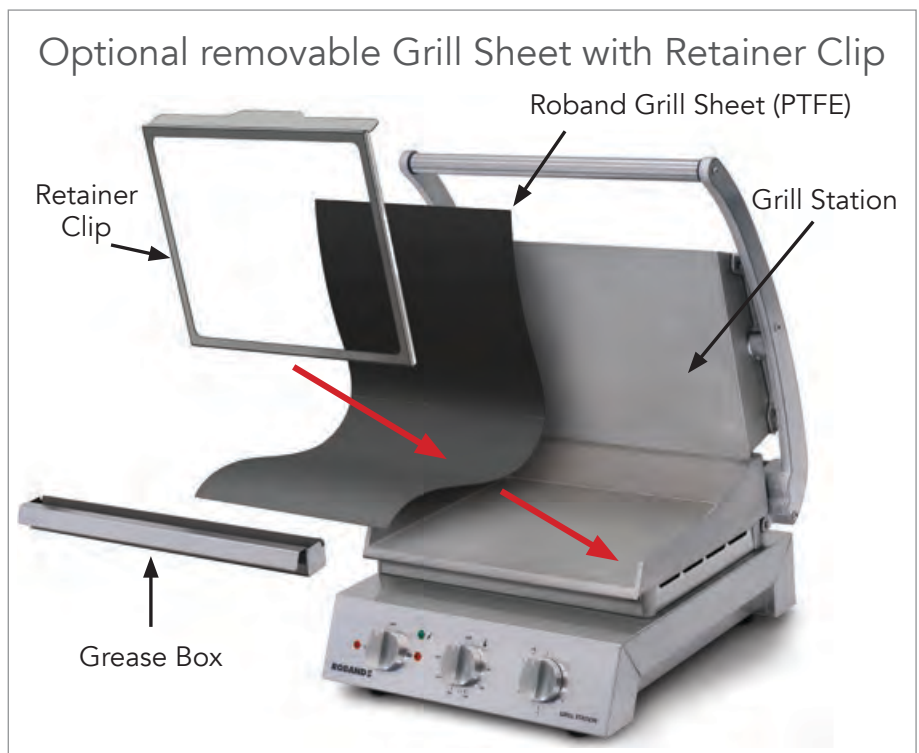

### Aluminium Grill Pattern Plate (for smooth plate Grill Stations only)

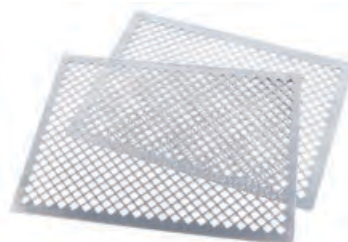

GS6-P1 set of 2 Aluminium Grill Pattern plates to suit 6 slice Grill Stations



Toasted food showing the pattern result



Showing easy installation on a Grill Station top plate



Showing easy installation on a Grill Station bottom plate

### Rear Stand



RS830 Rear Stand



GSA810S sitting on a Rear Stand RS830

## Grill Stations cont'd

### FEATURES & OPTIONS FOR ALL GRILL STATIONS

#### Side Draining Grease Channel



Side Draining Grease Channel on 8 slice Grill Station (pan not included) Only available for the Manual Timer models.

#### Spacers available in various sizes to suit



GSPS835 Spacer



GSPS845 Spacer inside a GSA810S

#### Spatula



Premium spatula pictured

### ACCESSORIES

GRILL STATION ACCESSORY		MODEL TO SUIT 6 SLICE GRILL STATIONS	MODEL TO SUIT 8 SLICE GRILL STATIONS
	Sheet Retainer Clip	RC6	RC8
	Grill Sheet (PTFE) (non-stick)	PGS605 (5 pack QTY) PGS610 (10 pack QTY)	PGS805 (5 pack QTY) PGS810 (10 pack QTY)
	Side Draining Grease Channel (Only available for the Manual Timer models.)	GC6	GC8
	Premium Spatula	SP12 (12 pack)	SP12 (12 pack)
	Rear Stand	RS630	RS830
	Plate Spacer	GSPS625 GSPS635 GSPS645	GSPS825 GSPS835 GSPS845
	Aluminium Grill Pattern Plate (suits smooth plate Grill Stations only)	GS6-P1 (a set of 2)	GS8-P1 (a set of 2)

## Grill Max Wide-Mouth Toaster

With peak performance and operator safety features, these high performance wide-mouthed toasters will make your conventional toaster a thing of the past. The wider mouth opening and larger toasting room increases menu options, and is ideal for the preparation of taller dishes. The internal fan reduces external surface temperatures. The added feature of an electronic timer with a soft, one-touch operation allows you to set your preferred time duration.



GMW815E

### FEATURES

- Electronic “soft-touch” timer operation
- 5 minute timer operation
- Set and forget timer with soft one-touch operation for repeat selection
- Top and bottom OR top only heat selection
- Energy regulator control allows for choice and flexibility in heat setting
- Stylish stainless steel design ideal for front-of-house environment
- Dura-life stainless steel elements for prolonged element life
- Wide mouth opening can accommodate dishes as tall as 100 mm
- Larger toasting room enables diversity in menu planning
- Cooling fan reduces external surface temperatures for operator safety
- Removable rack runners for easy cleaning
- Removable crumb tray for easy cleaning
- Audible alarm and flashing light at the end of the cooking cycle

One-touch timer  
- set and forget



Removable rack runners

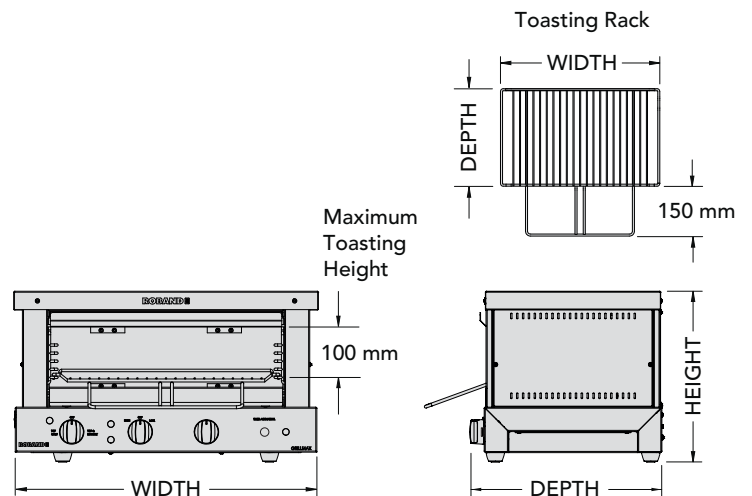

### SPECIFICATIONS

MODEL	SLICES No.	POWER Watts	CURRENT Amps	TIMER Mins	DIMENSIONS w x d x h (mm)	RACK DIMENSIONS w x d (mm)	TOASTING HEIGHT Max (mm)
GMW815E	8	3450	15.0	5	625 x 390* x 350	465 x 280	100

\*Depth does not include protruding rack. Including rack, depth is 505 mm.

## Grill Max Toasters



The Roband Grill Max toaster series is a statement of minimalist design with great functionality. It's timeless look belies a machine that is simple to use, functional, reliable and economical.

Used for a variety of food preparation, from grilled food to open melts and toasted sandwiches these machines are well designed to maximise speed whilst operating efficiently.

For energy efficient operation, set the energy regulator to a low setting to keep elements warm. When the timer dial is turned on, full power is delivered to elements for toasting during the timed period, overriding the low setting and with a *quick heat up time*. The Grill Max toaster then reverts back to the low temperature to *keep food warm until ready to be removed and served*.

Featuring either stainless steel elements for *prolonged element life* and good heat retention or glass elements for *rapid heat up time*. Both types of machine deliver outstanding results and the two options exist to suit customers' preferences.

### FEATURES FOR STEEL ELEMENTS

- Dura-life stainless steel elements for prolonged element life
- Good heat retention - continues to radiate some heat after elements turned off to help keep food warm

### SPECIFICATIONS FOR STEEL ELEMENT MODELS

MODEL	SLICES No.	POWER Watts	CURRENT Amps	TIMER Mins	DIMENSIONS w x d* x h (mm)	RACK DIMENSIONS w x d (mm)	TOASTING HEIGHT Max (mm)
GMX610	6	1960	8.5	5	485 x 315* x 315	355 x 240	79
GMX810	8	2300	10.0	5	585 x 315* x 315	455 x 240	79
GMX815	8	3360	14.6	5	585 x 315* x 315	455 x 240	79
GMX1515	15	3360	14.6	10	690 x 405* x 315	560 x 335	77

\*Depth does not include protruding rack.



GMX610



GMX810



GMX1515

## CONTROLS & FEATURES FOR ALL GMX TOASTERS

- Stylish brushed stainless steel body
- Energy regulator control
- 5 minute timer with bell
- Easy-clean removable crumb tray & reflector
- Top and bottom or top only heat selection
- Multiple rack positions

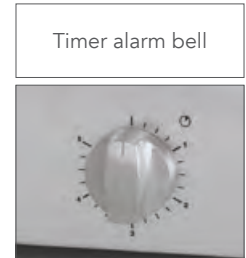
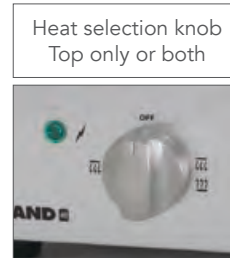
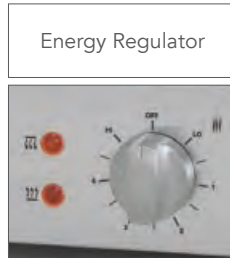

GMX810G glass element toaster



## FEATURES FOR GLASS ELEMENTS

- Glass elements heat up quickly and provide instant toasting power
- Wire guard protects glass elements from accidental impact from wire rack movement
- Glass elements are wired in parallel so that the machine continues to operate if one glass element stops functioning
- Top and bottom or top only heat selection

## SPECIFICATIONS FOR GLASS ELEMENT MODEL

MODEL	SLICES No.	POWER Watts	CURRENT Amps	TIMER Mins	DIMENSIONS w x d* x h (mm)	RACK DIMENSIONS w x d (mm)	TOASTING HEIGHT Max (mm)
GMX810G	8	2300	10.0	5	585 x 315* x 355	455 x 240	72

\*Depth does not include protruding rack.

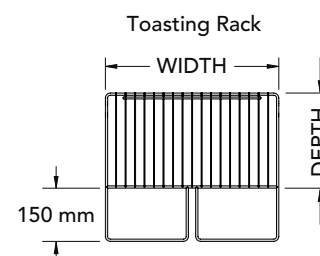
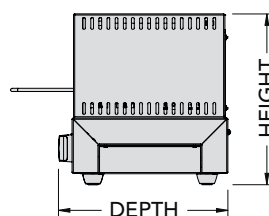
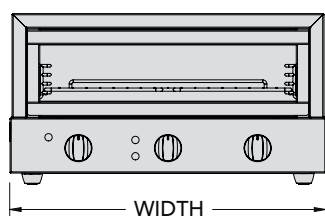

## Frypod Counter Top Fryers

Breaking ground with its innovative design, the Roband Frypod excels with its performance, safety and cleanliness of operation.

Delivering perfectly fried food time after time, the responsiveness of the Frypod elements to any drop in temperature has been honed and the temperature band that the fryer continues to operate in when loaded with food has been tightened.

This ensures that the temperature drop of the oil is minimised during the cooking process, delivering consistent, perfect results. It also means less oil in the food and longer oil life.

With a modern brushed stainless steel finish, the sleek exterior also houses a simple but clever safety lock mechanism that prevents users from removing the elements when the machine is switched on and prevents the machine from being turned on when the elements are removed.



Smart safety lock mechanism prevents element removal when machine is on



Elements swing back and lock in place for element draining and tank removal



Bevelled fryer body providing a lip for easy tank removal



## Single Pan Frypods



FR15

### FEATURES

- Precise thermostat control
- Modern brushed stainless steel finish
- Splashguard with bash plate that returns oil to tank
- Safety lock mechanism prevents element removal when machine is on
- Elements swing back and lock in place for draining and tank removal
- Bevelled fryer body for easy tank removal
- Safety over-temperature cut-out
- Max & min oil level markers
- Element guard and capillary protection
- Multi-functional fryer lid included
- Isolating switch
- Insulated basket handle

### SPECIFICATIONS

MODEL	TANK Litres	POWER Watts	CURRENT Amps	MACHINE DIMENSIONS ^ w x d x h (mm)	HEAT UP TIME, Mins (25 - 180 °C)	THAWED CHIPS PROD. Kg/Hr	FROZEN CHIPS PROD. Kg/Hr	BASKET SIZE* w x d x h (mm)
FR15	5	2300	10.0	290 x 480 x 335	11	7	6.5	215 x 215 x 137
FR18	8	3450	15.0	290 x 480 x 385	13	10.5	10	215 x 215 x 137

\*All these models have the same basket chip capacity of 1 Kg. ^Depth does not include protruding basket handle.

# Single Pan/Double Basket Frypods

Double basket flexibility in a single pan fryer. Conserve counterspace and still retain the ability to prepare individual orders or to coordinate dishes with different cooking times.



FR111

## FEATURES

- All the features of the single pan Frypods with double basket flexibility

## SPECIFICATIONS

MODEL	TANK Litres	POWER Watts	CURRENT Amps	MACHINE DIMENSIONS ^ w x d x h (mm)	HEAT UP TIME, Mins (25 - 180 °C)	THAWED CHIPS PROD. Kg/Hr	FROZEN CHIPS PROD. Kg/Hr	BASKET SIZE* w x d x h (mm)
FR111	11	3450	15.0	555 x 480 x 335	18	14	12.5	215 x 215 x 137

\*Basket chip capacity of 1 Kg. ^Depth does not include protruding basket handles.

# Double Pan Frypods

Featuring two pans and two baskets

the choice is yours, double the quantities, stagger the orders or keep food separate.

## FEATURES

- Precise thermostat control
- Modern brushed stainless steel finish
- Safety lock mechanism prevents element removal when the machine is on
- Elements swing back and lock in place for draining and tank removal
- Bevelled fryer body for easy tank removal
- Splashguards with bash plate that returns oil to tank
- Multi-functional fryer lids included
- Safety over-temperature cut-out
- Max & min oil level markers
- Element guard and capillary protection
- Insulated basket handles
- Isolating switch



FR28 with pan covers



FR25



## SPECIFICATIONS

MODEL	TANK Litres	POWER Watts	CURRENT Amps	MACHINE DIMENSIONS ^ w x d x h (mm)	HEAT UP TIME, Mins (25 - 180 °C)	THAWED CHIPS PROD. Kg/Hr	FROZEN CHIPS PROD. Kg/Hr	BASKET SIZE* w x d x h (mm)
FR25	2 x 5	2 x 2300	2 x 10.0	570 x 480 x 335	11	14	13	215 x 215 x 137
FR28	2 x 8	2 x 3450	2 x 15.0	570 x 480 x 385	13	21	20	215 x 215 x 137

\*All these models have the same basket chip capacity of 1 Kg. ^Depth does not include protruding basket handles.

## F Series Single Pan Fryers



Counter top frying at its simplest, with all the power and efficiency of the larger models, your Roband single pan fryer will *provide high performance whilst freeing up valuable counter top space.*



F15 with pan cover

### FEATURES

- Stainless steel construction
- Precise thermostat control
- Swing back element
- Maximum & minimum oil level markers
- Easily removable tank
- Isolating switch
- Insulated basket handle
- Element guard & capillary protection
- Safety over-temp cut-out
- Pan cover included

### SPECIFICATIONS

MODEL	TANK Litres	POWER Watts	CURRENT Amps	MACHINE DIMENSIONS ^ w x d x h (mm)	HEAT UP TIME, Mins (25 - 180 °C)	THAWED CHIPS PROD. Kg/Hr	FROZEN CHIPS PROD. Kg/Hr	BASKET SIZE* w x d x h (mm)
F15	5	2300	10.0	275 x 425 x 340	11	7	6.5	215 x 215 x 137
F18	8	3450	15.0	275 x 425 x 390	13	10.5	10	215 x 215 x 137

\*All these models have the same basket chip capacity of 1 Kg. ^Depth does not include protruding basket handle.

## F Series Single Pan/Double Basket Fryers

*Double basket flexibility in a single pan fryer.*

Conserve counterspace and still retain the ability to prepare individual orders or to coordinate dishes with different cooking times.

### FEATURES

- All the features of the single pan fryer with double basket flexibility



F111

### SPECIFICATIONS

MODEL	TANK Litres	POWER Watts	CURRENT Amps	MACHINE DIMENSIONS ^ w x d x h (mm)	HEAT UP TIME, Mins (25 - 180 °C)	THAWED CHIPS PROD. Kg/Hr	FROZEN CHIPS PROD. Kg/Hr	BASKET SIZE* w x d x h (mm)
F111	11	3450	15.0	545 x 425 x 340	18	14	12.5	215 x 215 x 137

\*Basket chip capacity: F111 = 1 Kg. ^Depth does not include protruding basket handles.



# F Series Double Pan Fryers

With two pans and two baskets the choice is yours. Double the quantities, stagger the orders or keep food separate. *Whatever the purpose, the Roband double pan fryers will open up the options.*



F25

## FEATURES

- Stainless steel construction
- Precise thermostat control
- Swing back element
- Maximum & minimum oil level markers
- Safety over-temp cut-out
- Insulated basket handles
- Isolating switch
- Element guard & capillary protection
- Easily removable tank
- Pan covers included



## SPECIFICATIONS

MODEL	TANK Litres	POWER Watts	CURRENT Amps	MACHINE DIMENSIONS ^ w x d x h (mm)	HEAT UP TIME, Mins (25 - 180 °C)	THAWED CHIPS PROD. Kg/Hr	FROZEN CHIPS PROD. Kg/Hr	BASKET SIZE* w x d x h (mm)
F25	2 x 5	2 x 2300	2 x 10.0	545 x 425 x 340	11	14	13	215 x 215 x 137
F28	2 x 8	2 x 3450	2 x 15.0	545 x 425 x 390	13	21	20	215 x 215 x 137

\*All these models have the same basket chip capacity of 1 Kg. ^Depth does not include protruding basket handles.

# Donut Fryer

*Produce perfect donuts every time.* Designed specifically for donut frying, the shallow pan ensures *optimum temperatures and recovery times for perfect results.*

## FEATURES

- Safety over-temp cut-out
- Isolating switch
- Swing back element
- Precise thermostat control
- Element guard
- Stainless steel construction
- Side trays, racks and lifters included



FD10

## SPECIFICATIONS

MODEL	TANK Litres	POWER Watts	CURRENT Amps	MACHINE DIMENSIONS ^ w x d x h (mm)	HEAT UP TIME Mins (25 - 180 °C)	RACK SIZE w x d (mm)
FD10	8.5	2300	10.0	380 x 485 x 290	20	340 x 295

^Depth does not include protruding basket handle.



## Freestanding Electric Fryers



The Austheat 3 phase electric fryers are ideal for take away shops or where high-speed production of fried food, such as fish and chips, is required.



AF812



AF822



AF813

### AF812 Single Pan 29 Litres 14.5 kW

The Austheat AF812 has a single pan and comes complete with two heavy-duty, stainless steel baskets and lid. With robust stainless steel construction and a tank thickness of 1.5 mm, the AF812 will give you years of trouble free service in the production of quality fried foods.

### AF812R (Rapid Recovery) 16.6 kW

Featuring 16.6 kW of power the AF812R is designed to perform where the demand for quick recovery is extreme.

### AF822 Twin Pan 2 x 14 Litres 14 kW

This compact high performance fryer has two separate tanks with individual controls. These provide the ability to operate the tanks at different temperatures, to separate flavours or to shut down one tank in quieter periods. The AF822 comes complete with two heavy-duty, stainless steel baskets, two lids and has all the features of the other fryers in the range.

### AF813 Single Pan 39 Litres 16.6 kW

This high performance single pan fryer has been specifically designed for the production of high volumes of fried foods. It is equipped with three heavy-duty, stainless steel baskets and a lid but can be used stand-alone for wet batters. Construction is similar to that of the AF812.

### AF813R (Rapid Recovery) 21.5 kW

With 21.5 kW of power the AF813R is designed to perform in the most demanding environment.



## SPECIFICATIONS

MODEL	BASKETS No.	TOTAL POWER	TOTAL CURRENT Amps	PHASE	OIL CAPACITY	COOKING TIME* (per 1.5 kg)	HOURLY OUTPUT PER HOUR* (frozen), (thawed)	HEAT UP TIME (to 185 °C)
SINGLE TANK								
AF812	2	14.5 kW	63.0	3 (+N)	29 litres	2-3 mins	32 kg, 39 kg	10 mins
AF812R	2	16.6 kW	72.3	3 (+N)	29 litres	2-3 mins	35 kg, 42 kg	9 mins
AF813	3	16.6 kW	72.3	3 (+N)	39 litres	2-3 mins	40 kg, 49 kg	10 mins
AF813R	3	21.5 kW	93.6	3 (+N)	39 litres	2-3 mins	45 kg, 55 kg	8.5 mins
DOUBLE TANK								
AF822	2	14.0 kW	60.9	3 (+N)	2 x 14 litres	2-3 mins	32 kg, 39 kg	10 mins

\*Approximate productivity 12 mm sq. blanched chips.

### Electric vs Gas

The benefits of electric fryers are significant - from contributing to a cleaner work place, to providing financial savings. Maintaining a cooler, more pleasant work environment is possible as electric fryers generally add less heat to your kitchen than gas fryers. Additionally, as there is no gas flame, Austheat fryers deliver a cleaner, healthier working environment by not burning the available oxygen, or emitting burnt and unburned gases into your kitchen.

### Longevity

Electric emersion elements tend to greatly outlast gas burners and their replacement costs are considerably less. Additionally, tank deterioration that is so prevalent in gas fryers is negligible in electric fryers.

### Energy efficient

In electric fryers, the majority of the energy from electricity is supplied directly into the elements, which are immersed in the oil, providing a very energy efficient solution and quick recovery time when loading food into the fryer. In the case of gas fryers, much of the energy is ultimately lost in the flue.

### High performance

Designed to achieve a balance of high output and fast recovery, Austheat electric fryers consistently deliver fried food of the highest quality, while maximizing the life of your oil.

### Easy to clean

Austheat fryers feature elements that swing out and up in seconds, providing access to a smooth, open, square tank for easy cleaning. There are no gas pipes to clean around and under, nor awkward crevices to access to thoroughly clean as can be the case with gas fryers.



## Freestanding Electric Fryers cont'd

### Dual control thermostats for efficiency and peace of mind

Each tank has a cook/idle switch that allows you to quickly switch between two temperature settings. Each cook/idle switch is linked to two thermostats housed behind the bottom door – one thermostat can be programmed with a cook temperature and the other with an idle temperature setting, reducing operating costs. The dual thermostats provide peace of mind that in the unlikely event of a thermostat failure, where the secondary thermostat can be set to cook temperature to allow you to continue operating.

Rear castors and adjustable front legs for complete manoeuvrability



Fishplate, element cover and cool zone below elements to prolong your oil life



Open tank provides clear access for easy cleaning

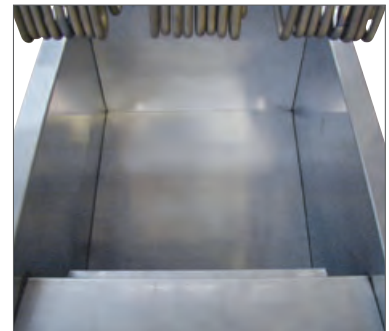

### Safety thermostats

All units are fitted as standard with manual reset over-temperature safety cut-outs.

### Cool zone

All Austheat fryers provide a cool zone that collects crumbs. The cool zone prevents the burning of crumbs so that the oil is not tainted by a burnt flavour. It also prolongs the life of the oil.

Pan covers included. (AF822 pictured)



Fryers can be joined together modularly using the tank joining cover (SS1794)



Melt cycles on all thermostats for use with solid cooking oil. Twin tank model pictured on the left. Single tank models pictured on the right.



Easy to read LED digital temperature display



Cook idle switch for quick control



Dual control thermostats for peace of mind



Wide 25 mm (1") diameter drain pipe with lockable ball valve. 150 mm drain tube extension also included.



Tilt up elements for safe and easy cleaning of tank

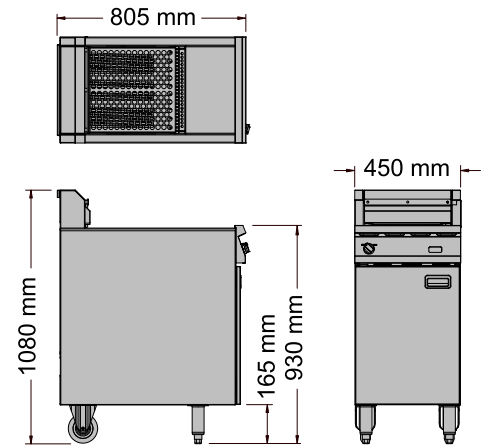

AF812 & AF812R dimensions

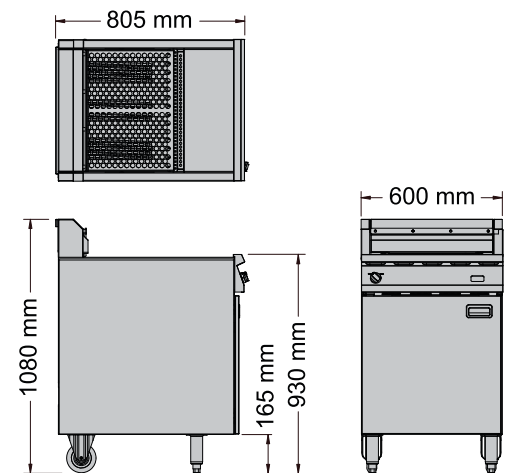

AF813 & AF813R dimensions

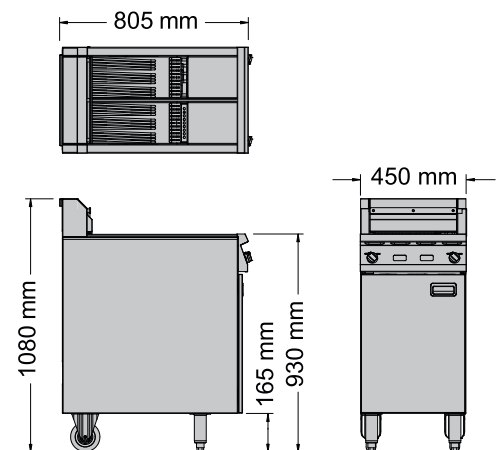

AF822 dimensions

## Freestanding Hotplate/Grill



The electric Austheat hotplate grill is the ideal solution for busy fast food outlets where high speed grilling and toasting is required. Ideal as a hamburger or grill station, the Austheat hotplate/grill is designed to work either as a stand alone machine or alongside Austheat deep fryers in a modular configuration.

### FEATURES

AHT860 with toasting or salamander function:

- The grill below the hotplate has a dedicated element for perfect one-sided toasting or salamander function. This is unlike many other brands available in the market that use the heat from the hotplate surface for toasting, which can result in uneven toasting. The heat output of the toaster is controlled by an energy regulator.
- The toaster also has a cook/idle setting. The twin energy regulator controls enable one heat setting to cook and another heat setting for idle periods so the chef can quickly switch between high and low settings in busy or quiet periods. It additionally provides a backup in the unlikely instance of a primary energy regulator failure.
- Each of the two cooking surface sections is controlled by its own cook/idle switch. Each cook/idle switch has two thermostats - one to control the temperature when switched to "Cook" and the other to control the temperature when switched to "Idle". This feature allows the Chef to quickly turn the temperature of the machine up to "Cook" and down to an "Idle" heat setting in quieter times to conserve electricity. The twin thermostat has the added benefit of providing a backup in the unlikely event of a primary thermostat failure.
- Easily readable twin digital temperature displays depict plate temperature.



AHT860



AH860

AH860 with extra storage space:

- The extra storage space under the steel hotplate is ideal for storing plates or cooking materials.
- Removable shelf for easy cleaning – 3 step adjustment

Both the AH860 & AHT860:

- A 12 mm thick heavy-duty machined steel hotplate cooking surface, providing the temperature and heat retention required for efficiently cooking a variety of grilled foods such as hamburgers, steak, eggs, bacon and pancakes. Features separate controls for the left side and right side of the hotplate providing flexibility in the use of the cooking surface area and ability to conserve electricity by only heating the cooking surface space required.
- Castors on the rear and adjustable legs at the front.



## FEATURES

AHT860 Cook/idle switches. Left controls 2/3 of plate, right controls 1/3 of plate



AHT860 Twin digital displays. One for each side of the hotplate



AHT860 toasting section is controlled by a separate energy regulator



## SPECIFICATIONS

MODEL	HOTPLATE POWER	TOASTER POWER	TOTAL POWER	TOTAL CURRENT Amps	PHASE	COOKING PLATE AREA	APPROX. TOASTING AREA	TOASTING HEIGHT CLEARANCE
AHT860	10.5 kW	1.7 kW	12.5 kW	54.5	3 (+N)	645 x 585 mm	490 x 410 mm	135 mm
AH860	10.5 kW	N/A	10.5 kW	45.7	3 (+N)	645 x 585 mm	N/A	N/A

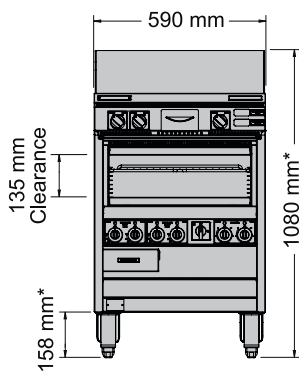

AHT860

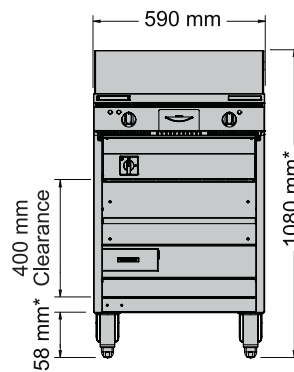

AH860

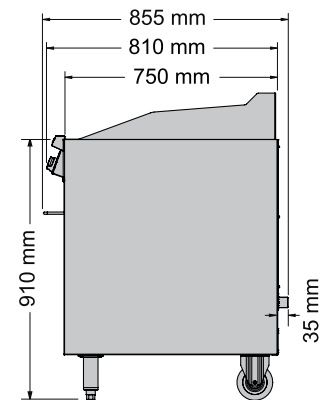

AHT860 & AH860

\* Varies with foot adjustments.

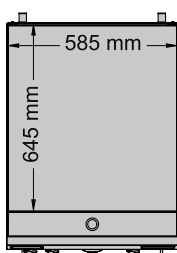

Hotplate for AHT860 & AH860

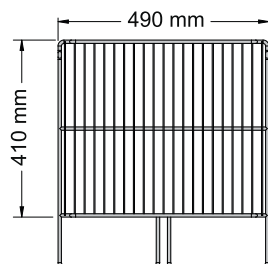

Toaster Rack for AHT860



## Conveyor Toasters

When it comes to serving large quantities of toasted bread, crumpets or muffins in a hurry, Roband conveyor toasters are the answer. With the capacity to toast up to 500 slices per hour\*, this toaster can handle the heaviest demands. Add the convenience of the front load/front return feature and you have an unbeatable combination.



### FEATURES

- Stainless steel body
- Selectable heat source top or bottom or both together
- Front entry, adjustable front return or pass through exit chute
- Variable electronic conveyor speed control
- Cover for speed controller switch so guests don't alter setting
- Easy-clean crumb tray & reflector
- Dura-life stainless steel elements for prolonged element life



TCR15 pictured.  
TCR10 looks identical.

Adjustable front or rear exit chute (rear exit pictured)	Easily removable crumb tray & reflector	Speed controller cover
		

### SPECIFICATIONS

MODEL	SLICES/HR (up to)	POWER Watts	CURRENT Amps	DIMENSIONS w x d x h (mm)
TCR10	300*	2300	10.0	475 x 430 x 370
TCR15	500*	3220	14.0	475 x 430 x 370

\*Variations may occur depending on voltage supply and bread product (see page 62).

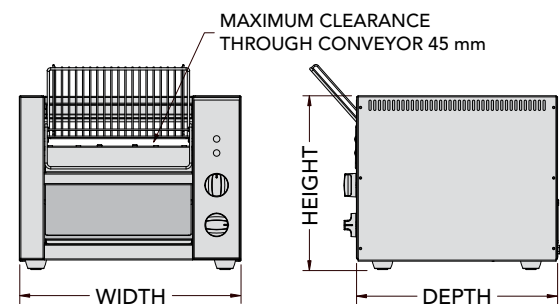





# Eclipse Bun & Snack Toasters

Providing ultimate toasting control for back-of-house kitchen staff, the Eclipse is designed for high speed bun toasting and toasting of small bread based snack items. The machine provides precise and independent variable heat control of the top element and bottom element to enable users to produce the desired result on each side of their product.



## FEATURES

- Modern brushed stainless steel construction
- Independent and precise variable control of top and bottom element heat output
- Solid State Electronics offer precise temperature control and greater component reliability, creating the exact toasting environment to suit many products
- Control of conveyor belt speed
- Two entry chutes providing different entry angles, standard wire 48° or stainless steel 25°
- Front return or pass through chute operation
- Adjustable angle on rear chute – 3 angles (10°, 17.5°, 25°)
- Dura-life stainless steel elements for prolonged element life
- Removable crumb trays for easy cleaning
- 40 mm entry chute clearance
- Maximum toasting diameter up to: return chute 130 mm, pass-through 310 mm



ET315 pictured.  
ET310 looks identical.



ET315 showing front chute and rear chute at adjustable angles.  
ET310 looks identical.



ET315 showing rear pass through chute. ET310 looks identical.

## SPECIFICATIONS

MODEL	BREAD SLICES/HR (up to)	BUN HALVES/HR (up to)	POWER Watts	CURRENT Amps	DIMENSIONS w x d x h (mm)
ET310	300*	270*	2300	10.0	480 x 495 <sup>^</sup> x 400 <sup>^</sup>
ET315	500*	370*	3260	14.2	480 x 495 <sup>^</sup> x 400 <sup>^</sup>

\*Variations may occur depending on voltage supply and bread product (see page 62).

<sup>^</sup>Depth and height does not include protruding racks/chutes.

## Sycloid® Toasters

Elegantly designed and crafted, the revolutionary Sycloid® toaster sets the standard for high speed toast production. The Sycloid's stylish exterior houses a *cleverly engineered machine that provides truly functional energy efficient operation and an outstanding toasting result time after time.*

 **sycloid®**  
TOASTER



### FEATURES

- Available in red, black or natural colours with the option of either 10 amps producing over 350\* slices per hour, or 13 amps, producing over 500\* slices per hour.
- All Sycloid toasters deliver excellent toasting results for bread up to 30 mm thickness. As most bread used in buffets is expected to be less than 20 mm thickness, the Sycloid is optimised to deliver its best result for bread of this thickness, can accommodate slices up to 30 mm.
- Patron and staff safety is paramount and the Sycloid® toaster has been designed with "cool to touch" external surfaces and a lid locking latch.
- Intelligent energy efficient design – an automatic energy-save mode conserves energy during quiet periods by scaling back power consumption and switching off the conveyor when in energy save mode. The intelligent auto-sense feature detects when a new slice of bread is placed in the machine and automatically prepares the machine to toast the bread. The heat setting in this mode is balanced and optimised to ensure quick recovery. Energy save mode can be disabled so the machine runs at full power if desired.
- A user-friendly and reliable speed controller allows adjustment of the toasting time to account for different types of bread to be toasted. The knob setting lock feature allows staff to set the toasting speed, removing the risk of patrons altering the setting.
- Diners can easily see when their toast is ready from across the buffet with the stylishly sculpted toast return chute with LED lighting that provides easy and illuminated viewing of the toast holding bay. The wide opening of the bay allows easy access to toast, which the radiant heat from the elements helps to keep warm.
- Featuring robust stainless steel elements, the Sycloid® toaster also features a modern brushed stainless steel exterior, perfect for disguising finger prints on a machine expected to be heavily used. It also includes a slide-out crumb tray for every-day cleaning and a hinged top cover allowing easy access to clean the inside.
- The Sycloid® toaster produces a beautiful toasting result throughout the entire slice of bread.

\* Dependent on bread type.



# The Hottest Toaster that's "Cool-to-Touch"

## FEATURES

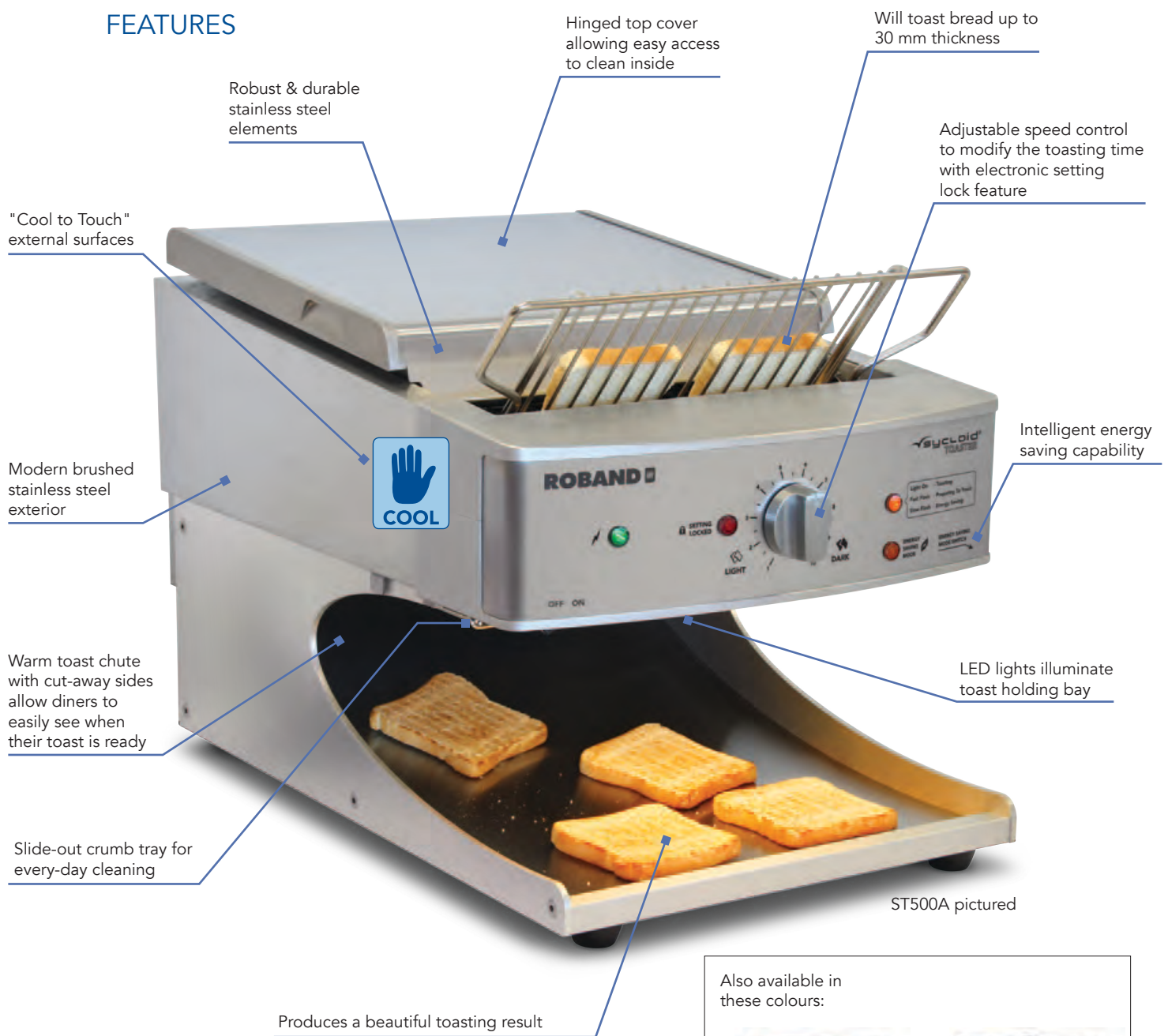

## Sycloid® Toasters cont'd

### FEATURES

Toasting speed controller with electronic lock setting feature	Indicator light for auto-sensing feature	Removable crumb tray for ease of cleaning	Lid-lock release lever to lift lid
LED lights illuminate the toast holding bay	Hinged top cover for easy access to clean inside		

### SPECIFICATIONS

MODEL	COLOUR	SLICES / HR (min)	CURRENT Amps	POWER Watts	DIMENSIONS W x D x H (mm)	WEIGHT Kg
ST350A	Natural	350	10.0	2300	415 x 600 x 425	25
ST350AR	Red	350	10.0	2300	415 x 600 x 425	25
ST350AB	Black	350	10.0	2300	415 x 600 x 425	25
ST500A	Natural	500	13.0	2990	415 x 600 x 425	25
ST500AR	Red	500	13.0	2990	415 x 600 x 425	25
ST500AB	Black	500	13.0	2990	415 x 600 x 425	25

### DIMENSIONS

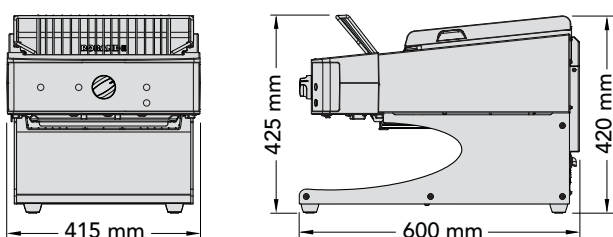

## Vertical Toasters

These vertical toasters can accommodate their maximum number of slices or a reduced number of 2 slices in quieter periods. Both models utilise an automatic element timer for consistent results. *Once cooked, the toast can remain warm in the machine* before being manually ejected. Designed for continuous use.



TC66

### FEATURES

- Stainless steel construction
- 6 minute timer
- Easy-clean crumb tray
- Multi-slice selection<sup>#</sup>
- Dura-life stainless steel elements for prolonged element life
- Slot width 2.8 cm by 14 cm

### SPECIFICATIONS

MODEL	SLICES No.	POWER Watts	CURRENT Amps	DIMENSIONS w x d x h (mm)
TC55	2 or 5#	2200	9.6	420 x 265 x 312
TC66	2 or 6#	2570	11.2	420 x 265 x 312

<sup>#</sup>The TC55 is only designed to toast **2 or 5 slices at a time**. The TC66 is only designed to toast **2 or 6 slices at a time**. Manual ejection required.

Note: These models are designed for continuous use. A change in selection of the number of slices toasted will require a period for element temperatures to equalise. Uneven toasting may result during these transitional periods.

## Salamander



The Roband Salamander is ideal for grilling, top toasting and finishing off ingredients such as cheese, mornays and toppings. Fast, economical and versatile, the Roband salamander will quickly become an integral part of your busy kitchen.



SA15

### FEATURES

- Stainless steel construction
- Dual energy regulator control
- Dura-life stainless steel elements for prolonged element life
- Wall mount kit included
- Easy-clean crumb tray & reflector
- Powerful top only heating

### SPECIFICATIONS

MODEL	SLICES No.	POWER Watts	CURRENT Amps	DIMENSIONS w x d x h (mm)	RACK DIMENSIONS w x d (mm)
SA15	15	3200	13.9	690 x 455* x 355	560 x 345^

\*Depth does not include protruding rack. Including rack, depth is 495 mm.  
 ^Depth doesn't include handle. Including handle depth is 490 mm.  
 Maximum toasting height is 121 mm with toasting rack in lowest position.

## Griddles

From the outside, all brands of Griddles look quite similar but, it's what's inside a Griddle that determines how well the machine will perform under pressure and when you need it the most.



*Directs the heat where it needs to be!*

This is where Roband Griddles are set apart from the competition and *allow you to **precisely** cook a variety of food* from steaks, chicken, fish and burger patties, fritters to eggs and bacon.

All Roband griddles feature uniquely designed elements that provide maximum temperature penetration specifically into the thick, steel griddle plate. The unique element design results in a *smooth, controllable and even temperature across the cooking surface*.

Roband Griddles help you achieve:

- 1) Faster cooking times with rapid temperature recovery when loaded with food
- 2) Lower power consumption and heat losses
- 3) Even temperatures for professional cooking
- 4) Reliable food quality outcomes

Three Griddles are offered in the Roband range, each delivering best in class performance. Every machine plate size has been engineered to deliver the best cooking experience possible from the power supplied.

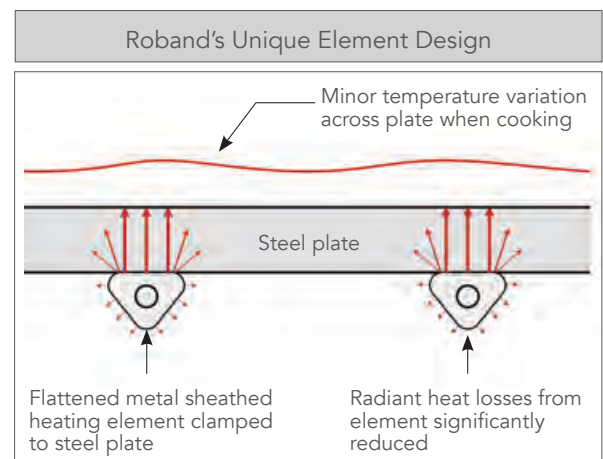

### FEATURES

- 8 mm thick griddle plates for superior heat retention
- Superior, compacted griddle plate elements for fast temperature recovery and reliable temperature control
- Thermostat control for precise cooking temperature. Dual on G700 for control of left and right side of plate
- Large capacity forward positioned grease box which is dual skin for lower touch temperatures and integrated into machine to reduce risk of spillage and minimise bench space



G500



G500XP



G700

### Griddle Selection Guide

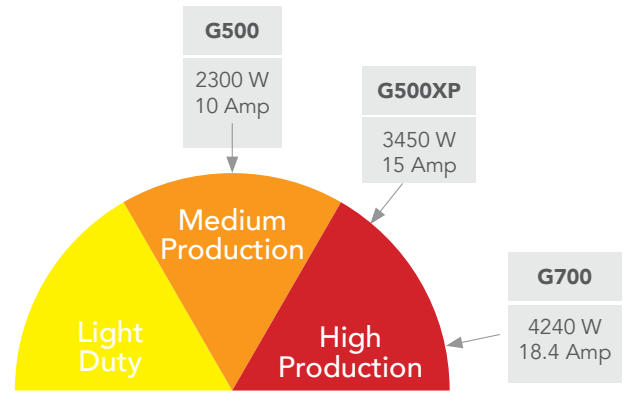

### SPECIFICATIONS

MODEL	POWER Watts	CURRENT Amps	PHASE	DIMENSIONS ^ w x d x h (mm)	COOKING SURFACE w x d (mm)
G500	2300	10	1	538 x 443 x 263	515 x 340
G500XP	3450	15	1	538 x 443 x 263	515 x 340
G700*	4240	18.4	1 or 2 (+N)	725 x 529 x 263	700 x 400

\*Installation must be carried out by a licensed electrician. For this reason, the G700 model does not come with a plug and cord. The decision on connection options should be made under consultation with your electrician. Can be wired for Single Phase or 2 phase + n. We recommend using more than 1 phase for this machine as multiple phases will help evenly balance load and will reduce stress on product components. ^Dimensions include grease box.

## Griddle Toasters



Griddle Toasters are the perfect combination machine to produce a great top toasting result, whilst precisely cooking your steaks, eggs, bacon or hamburgers on the griddle cooking plate.

Each model within the Roband Griddle Toaster range has been engineered to maximise the performance of the machine in both the griddle and toasting functions.

They all feature separate elements for the heavy steel griddle plate as well as the toasting compartments to ensure consistent and optimal results across both functions.

Three Griddle Toaster models are available:

1. **GT480** - honed to provide maximum punch from 10 Amps, caters to outlets that are limited by power supply, but still have a need for both griddle and top-toasting functions.
2. **GT500** – slightly larger plate size than GT480 with more power and grunt. Designed for medium to fast paced food production.
3. **GT700** - is for very busy operations with a need to produce significant volumes of food from a bench-top machine.

With a comprehensive, diverse and well-designed range of Griddle Toasters, a Roband solution can be found to suit almost any counter top application.

### FEATURES:

- 8 mm thick steel cooking plates for superior heat retention (GT480 features 6 mm plate)
- Superior, compacted cooking plate elements for fast temperature recovery and reliable temperature control
- Thermostat control for precise griddle plate cooking temperature.
- Dual element system has independent control of the toasting function and griddle plate function, providing optimum cooking control for kitchen staff. The toasting compartment of all models is designed to work in tandem with the hotplate operation. (Note GT480 toast elements do not have independent control. They are controlled by the On/Off switch)
- The larger GT700 model features independent operation of the left or right side of the griddle and toaster for efficient use in quiet periods
- Large capacity forward positioned grease box which is dual skin for lower touch temperatures and integrated into machine to reduce risk of spillage and minimise bench space
- Toasting crumb tray is removable for easy cleaning of toasting compartment

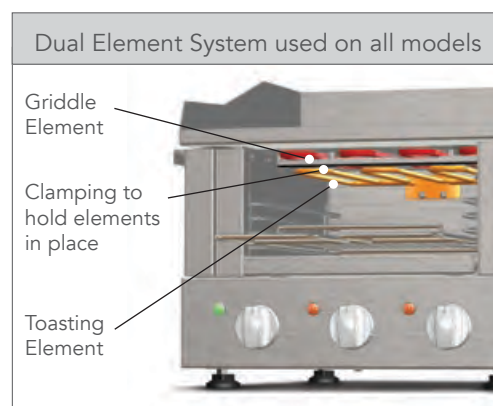





GT480



GT500



GT700

### Griddle Toaster Selection Guide

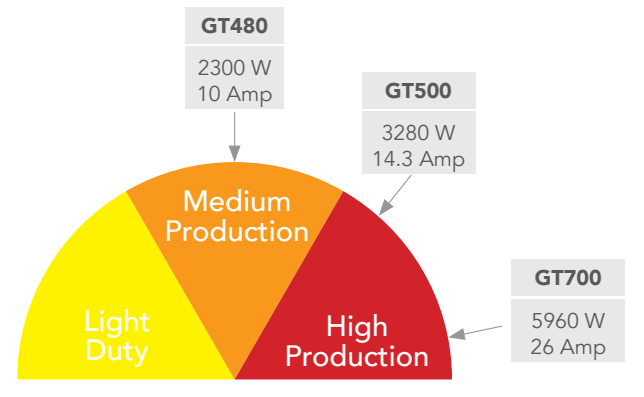

## SPECIFICATIONS

MODEL	POWER Watts	CURRENT Amps	PHASE	DIMENSIONS ^ w x d x h (mm)	COOKING SURFACE w x d (mm)	MAX. FOOD CLEARANCE (mm)
GT480	2300	10.0	1	495 x 425 x 374	480 x 308	70
GT500	3280	14.3	1	537 x 457 x 374	515 x 340	70
GT700*	5960	26.0	1, 2 or 3 (+N)	725 x 541 x 374	700 x 400	70

\*Installation must be carried out by a licensed electrician. For this reason, the GT700 model does not come with a plug and cord. The decision on connection options should be made under consultation with your electrician. Can be wired for Single Phase, 2 phase + n or 3 phase + n. We recommend using more than 1 phase for this machine as multiple phases will help evenly balance load and will reduce stress on product components. ^Dimensions include grease box and do not include the protruding rack.

## Pie Master Pie & Food Warmers

Stylishly designed, attractive and functional Pie Masters display food at the desired serving temperature. With a variety of sizes and options available, they set the standard for display of pies, sausage rolls and other pastry based hot foods.



Three sizes are available with capacity for 25, 50 or 100 pies. They all feature a modern, brushed stainless steel body with adjustable feet.

Racks can be installed horizontally or at an angle to enable contents to be displayed in the most appealing way.

“L” models feature an internal light to illuminate food as well as a steam pan seated in a baffle tray to produce a delicate steam to keep food moist.

### FEATURES

- Stylish brushed stainless design
- Variety of sizes up to - 25, 50 and 100 pie capacity
- Adjustable feet
- Easily removable crumb tray
- Display racks in each unit can be positioned horizontally or at an angle enabling the best display of contents.
- Stop rail on each shelf stopping food touching glass
- Sliding glass door variations (50 & 100 pie capacity models). Hinged glass door (25 pie capacity models)
- Stainless steel door & back variations for 50 & 100 pie capacity models



PM25L



PM50L



PM100L

### ADDITIONAL FEATURES - RANGE WITH LIGHTS

- Baffle tray with steam pan (1/9 gastronorm) in the base of the unit to provide moisture to contents
- Internal light to illuminate contents is easy to replace



## SPECIFICATIONS

MODEL	PIE CAPACITY	DOORS	INTERNAL LIGHT	POWER Watts	CURRENT Amps	DIMENSIONS w x d x h (mm)
PM25	25	Hinged glass door	No	1100	4.8	401 x 398 x 585
PM25L	25	Hinged glass door	Yes	1200	5.2	401 x 398 x 585
PM50	50	Glass doors single side	No	1250	5.4	610 x 392 x 507
PM50G	50	Glass doors both sides	No	1250	5.4	610 x 392 x 507
PM50L	50	Glass doors single side	Yes	1350	5.9	610 x 392 x 507
PM50LG	50	Glass doors both sides	Yes	1350	5.9	610 x 392 x 507
PM50S	50	Stainless steel doors & back	No	1250	5.4	610 x 392 x 507
PM100	100	Glass doors single side	No	1550	6.7	772 x 392 x 587
PM100G	100	Glass doors both sides	No	1550	6.7	772 x 392 x 587
PM100L	100	Glass doors single side	Yes	1650	7.2	772 x 392 x 587
PM100LG	100	Glass doors both sides	Yes	1650	7.2	772 x 392 x 587
PM100S	100	Stainless steel doors & back	No	1550	6.7	772 x 392 x 587

## Hammertone Finish Pie Warmers

Finished in silver hammertone on a steel body, all units have thermostat control, thermometer and removable crumb trays. Models 40DT and 80DT have removable drawers with stainless steel fronts and are designed for pies, pastries and sausage rolls. The 83DT has sliding steel doors, three removable wire shelves and is designed for pies and food containers. *Roband pie warmers are ideal for lunch rooms, canteens and construction sites.*

### FEATURES

- Precise thermostat control
- Easily removable shelves, doors, drawers and crumb tray for easy cleaning
- Double skin cavity for even temperature and low running costs
- Thermometer
- Single phase 10 Amp plug



40DT



83DT

### SPECIFICATIONS

MODEL	DESCRIPTION	PIE CAPACITY (Approx.)	POWER Watts	CURRENT Amps	DIMENSIONS w x d x h (mm)
40DT	4 removable drawers	40	1250	5.4	505 x 320 x 360
80DT	6 removable drawers	80	1250	5.4	585 x 350 x 485
83DT	Sliding steel doors	40	1250	5.4	585 x 350 x 485

## Multi-Function Chip & Food Warmer

The multi-function food and chip warmer is a compact bench-top warmer that can accommodate a range of accessories to suit the type of hot food being displayed. With heat source from above (quartz heat lamp) and from below (stainless steel elements), the unit attractively holds and displays hot food, ready for service.



Designed for better performance, extra reliability, safety & end-user serviceability...as well as visual appeal

### Heating:

- Sealed upper heating units with easy-change Halogen Heat LAMP (no electrician needed)
- Improved temperature control

### Safety:

- Dual Jacket heating lamp (if inner globes breaks, outer glass captures the glass pieces)

### Quality:

- Resilient build quality

### Aesthetics:

- Contemporary – styled look with brushed steel finish

### MW10 – Base Unit

The MW10 is supplied without any accessories or trays. It can accommodate a range of gastronorm pan configurations to suit the specific hot food being displayed. Combinations of pans up to a full sized 1/1 (100 mm deep) gastronorm pan can be accommodated. With heat from above and below, the MW10 can hold cooked food at correct serving temperature whilst being appealingly displayed.

MW10 - Base unit shown with optional 1/1 gastronorm pan, 100 mm deep (sold separately)



### MW10CS – Carving Station

The MW10CS is supplied with a full size (65 mm deep) gastronorm pan and a full size perforated and spiked pan (25 mm deep) so that the unit can be used as a carving tray. The perforated and spiked tray secures the meat for easy carving, whilst the larger pan sitting underneath holds water to produce steam and keep the meat moist and collects any fat drippings. The heat lamp throws a warm yellow light over the meat to enhance presentation.

MW10CS - Carving Station





## MW10CW & MW20CW – Chip Warmers

Supplied with a sloping tray for chips, the MW10CW and MW20CW are designed to enhance productivity and presentation of cooked chips. Heating from above and below, the unit maintains cooked chips at the correct serving temperature and allows the fryer basket to be immediately returned to the fryer for the next batch, increasing fryer productivity.

At the same time, the heat lamp serves to throw heat and a yellow light onto the cooked chips to enhance presentation.



MW10CW - Chip Warmer



MW20CW - Chip Warmer

## SPECIFICATIONS

MODEL	DESCRIPTION	POWER Watts	CURRENT Amps	DIMENSIONS w x d x h (mm)
MW10	Multi-function base unit fits 1/1 gastronorm pan (not included)	685	3.0	395 x 640 x 475
MW10CW	Multi-function Chip Warmer with sloped tray for chips	685	3.0	395 x 640 x 475
MW10CS	Multi-function Carving Station with 1/1 size 25 mm deep perforated & spiked carving pan and 1/1 size 65 mm deep pan underneath	685	3.0	395 x 640 x 475
MW20CW	Multi-function Chip Warmer with sloped tray for chips	1370	6.0	720 x 640 x 475

## Boiling Hot Plates

Portable power at its best. Whether you are on the move or simply need additional power in the kitchen, Roband boiling plates are the ideal solution. *Totally portable, these units have the power and versatility to simmer, boil or fry in any location.*



12

### FEATURES

- Six heat settings for each hot plate
- High speed recovery
- Sealed cast iron hot plates
- Stainless steel construction

### SPECIFICATIONS

MODEL	POWER Watts	CURRENT Amps	DIMENSIONS w x d x h (mm)	HOT PLATE DIAMETER (mm)
11	1840	8.3	300 x 255 x 105	1 x 190
12	2300	10.0	510 x 265 x 105	2 x 150
13	1840	8.3	360 x 282 x 105	1 x 230



13

## Coffee Warmer



The Roband coffee warmer will keep two pots of hot coffee at the correct serving temperature without allowing the coffee to be spoiled through boiling.

### FEATURES

- Stainless steel body
- Two illuminated on/off switches
- Attractive enamelled plates



KH2

### SPECIFICATIONS

MODEL	POWER Watts	CURRENT Amps	DIMENSIONS w x d x h (mm)
KH2	250	1.1	385 x 220 x 75



## Pasta Master/Vegetable Blancher

From fridge to table in moments. The Roband pasta master will return pre-prepared pasta dishes such as spaghetti, fettuccine and tortellini to serving temperature quickly and efficiently. This machine can also be used for blanching vegetables.



MP18

### FEATURES

- 18/10 Stainless steel construction
- Precise thermostat control 30-120 °C
- Easily removable tank
- Swing back element
- Stainless steel fine mesh baskets
- Pan cover included

### SPECIFICATIONS

MODEL	TANK Litres	POWER Watts	CURRENT Amps	DIMENSIONS w x d x h (mm)	BASKET SIZE* w x d x h (mm)
MP18	8	2240	9.7	275 x 425 x 340	100 x 215 x 145

\*2 x baskets.

## Hot Dog & Bun Warmers



Treat your customers to delicious, steaming hot dogs, with the Roband hot dog and bun warmer. The see-through glass tank presents the hot dogs appealingly and the models with spikes heat the buns for a perfect combination.

### FEATURES

- Stainless steel construction
- Energy regulator controls
- Heated aluminium spikes
- Optional Teflon® coated spikes
- Tank divider to separate heating and cooked product
- Available without spikes, model M1
- Available without steam tank, model M6T

### SPECIFICATIONS

MODEL	SPIKES	STEAM TANK	TEFLON® COATED	POWER Watts	CURRENT Amps	DIMENSIONS w x d x h (mm)
M1	0	YES	NO	700	3.0	350 x 270 x 300
M3	3	YES	NO	1000	4.4	350 x 350 x 300
M3T	3	YES	YES	1000	4.4	350 x 350 x 300
M6T	6	NO	YES	600	2.6	355 x 240 x 300



M3



M1



M6T

## Counter Top Bain Maries



Hold food at serving temperature with the convenience and style of a Roband counter top bain marie. With a comprehensive range of sizes and pan combinations, there is a counter top unit to suit every situation. There are 4 configurations available. The options suit either 1 x 1/2 size pan, 2 x 1/2 size pans sitting either side to side (wide) or front to back (narrow) and 4 x 1/2 size pan configuration. Each option can accommodate a variety of different sized pans as shown in the Specifications table. Heat control is either delivered by an energy regulator or thermostat\*. Thermostatically controlled machines end with the model suffix 'T'.

### FEATURES

- Stainless steel construction
- Dura-life stainless steel elements for prolonged element life
- Slimline thermometer
- Designed to take many combinations of gastronorm pans up to 150 mm deep
- Removable cross bar on BM4 model range only
- 1, 2 or 4 pan models available. 2 pan configuration available in narrow or wide footprint
- Safety lock ball valve drain on BM2, BM21 and BM4 models
- Double skin tank

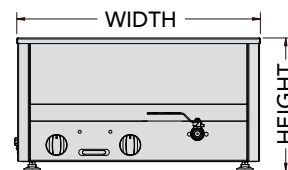
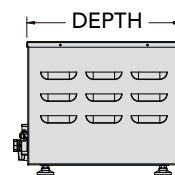

Refer to table on right hand page for model dimensions.

\*Thermostatically controlled machines end with the model suffix 'T'.





BM1A



BM21 (narrow footprint)



BM2B (wide footprint)



BM4E



## SPECIFICATIONS

MODEL	DESCRIPTION/ INCLUSIONS	ENERGY REG/ THERMOSTAT Control	OPERATION ^		POWER Watts	CURRENT Amps	DIMENSIONS* w x d x h (mm)
			Wet	Dry			
<b>1 x 1/2 SIZE PAN CONFIGURATION</b>							
BM1	Pan not included	Energy reg	Yes	No	670	2.9	355 x 305 x 320
BM1A	1 x 1/2 size 100 mm pan & lid	Energy reg	Yes	No	670	2.9	355 x 305 x 320
BM1B	1 x 1/2 size 150 mm pan & lid	Energy reg	Yes	No	670	2.9	355 x 305 x 320
BM1E	1 x 200 mm round (7.25 L) pot & lid	Energy reg	Yes	No	670	2.9	355 x 305 x 320
BM1T	Thermostat control, pan not included	Thermostat	Yes	No	670	2.9	355 x 305 x 320
<b>2 x 1/2 SIZE PANS CONFIGURATION - WIDE (2 Pans Wide x 1 Pan Deep)</b>							
BM2	Pans not included	Energy reg	Yes	Yes	1000	4.4	560 x 355 x 320
BM2A	2 x 1/2 size 100 mm pans & lids	Energy reg	Yes	Yes	1000	4.4	560 x 355 x 320
BM2B	3 x 1/3 size 100 mm pans & lids	Energy reg	Yes	Yes	1000	4.4	560 x 355 x 320
BM2C	3 x 1/3 size 150 mm pans & lids	Energy reg	Yes	Yes	1000	4.4	560 x 355 x 320
BM2E	2 x 200 mm round (7.25 L) pots & lids	Energy reg	Yes	Yes	1000	4.4	560 x 355 x 320
BM2T	Thermostat control, pans not included	Thermostat	Yes	No	1000	4.4	560 x 355 x 320
<b>2 x 1/2 SIZE PANS CONFIGURATION - NARROW (1 Pan Wide x 2 Pans Deep)</b>							
BM21	Pans not included, fits 2 x 1/2 size pans	Energy reg	Yes	Yes	1000	4.4	355 x 560 x 320
BM21T	BM21 with thermostat control 30 - 120 °C	Thermostat	Yes	No	1000	4.4	355 x 560 x 320
<b>4 x 1/2 SIZE PANS CONFIGURATION</b>							
BM4	Pans not included	Energy reg	Yes	Yes	1200	5.2	680 x 560 x 320
BM4A	4 x 1/2 size 100 mm pans & lids	Energy reg	Yes	Yes	1200	5.2	680 x 560 x 320
BM4B	6 x 1/3 size 100 mm pans & lids	Energy reg	Yes	Yes	1200	5.2	680 x 560 x 320
BM4C	6 x 1/3 size 150 mm pans & lids	Energy reg	Yes	Yes	1200	5.2	680 x 560 x 320
BM4E	4 x 200 mm round (7.25 L) pots & lids	Energy reg	Yes	Yes	1200	5.2	680 x 560 x 320
BM4T	Thermostat control, pans not included	Thermostat	Yes	No	1200	5.2	680 x 560 x 320

Note: Maximum pan depth 150 mm on all models.

^Machines should not be left unattended. \*Heights exclude pans, pots and lids.

## Sauce Warmer

With its 2 litre capacity, this versatile little compact unit excels when the quantities or location don't justify the use of a full size bain marie.

### FEATURES

- Versatile - keeps sauces and gravies warm
- Portable compact design makes it ideal for small or off-site functions
- Easy to clean with a removable stainless steel 1/6 size pan
- 2 litre pan holds between 20 and 30 servings of gravy or sauce
- Dry operation only



MH16



### SPECIFICATIONS

MODEL	POWER Watts	PAN CAPACITY	CURRENT Amps
MH16	125	1 x 1/6 size 150 mm plus lid	0.5

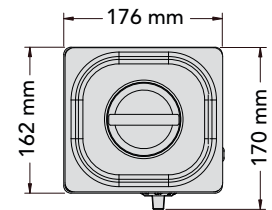
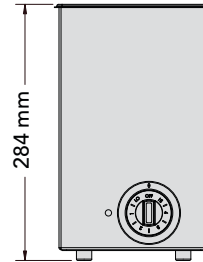

## Chocolate Bain Maries



Designed for holding the temperature of melted chocolate for food coating applications.

### FEATURES

- Designed to take various combinations of gastronorm pans
- Wet operation only ^
- Self-resetting thermal safety cut-out
- Double skin tank
- Thermostatically controlled (temperature range 20 - 50 °C)
- Stainless steel construction

^ Machines should not be left unattended.

### SPECIFICATIONS

MODEL	POWER Watts	PAN COMBINATION	CURRENT Amps	DIMENSIONS w x d x h (mm)
CHOC1A	670	1 x 1/2 size 150 mm plus lid	2.9	355 x 305 x 320
CHOC2A	1000	2 x 1/2 size 150 mm plus lids	4.4	560 x 355 x 320

Note: Available without pans. Delete "A" from Model No.



CHOC2A

# Hot or Refrigerated Bain Maries

This range of bain maries is designed to hold food at serving temperature. Available as either hot or refrigerated units.

## FEATURES - HOT & REFRIGERATED

- All stainless steel construction with tubular frame
- Removable cross bars
- Safety lock ball valve drain
- Trolleys available, see page 51

## FEATURES - HOT

- Wet or dry operation ^
- Dura-life stainless steel elements for prolonged element life
- Energy regulator control
- Designed to take many combinations of gastronorm pans up to 100 mm deep
- Thermometer display

^ Machines should not be left unattended.

## FEATURES - REFRIGERATED

- Refrigerated cold plate\* running high quality R404A refrigerant
- Refrigerated condensing units can be supplied separately for remote installation
- Streamlined for easy cleaning
- Adjustable digital thermostat with temperature readout
- Quiet operation

See pages 50 - 52 for all optional accessories.

Note: All BM and BR bain maries can be manufactured with no corner legs for built-in bench mounting. When ordering please specify by prefixing the model number with the letters NC e.g. NCBM24 (NC signifies 'no corner legs'). These items are made to order and are non-returnable.

\*Safety regulations require careful preparation, handling and storage of food products at all times. Cold plate units operate with a single refrigeration coil attached to the underside of the tank, thus food is chilled from underneath. Users must be absolutely certain that a single refrigeration coil will suit their purpose and is in compliance with food safety standards.



BM25A hot bain marie



BR25 refrigerated bain marie pictured with pans added

## SPECIFICATIONS

MODEL	POWER Watts	PAN COMBINATION	CURRENT Amps	DIMENSIONS w x d x h (mm)
HOT - PANS & LIDS INCLUDED				
BM14A	1650	4 x 1/2 size x 100 mm ~	7.2	1135 x 408 x 255
BM16A	1550	6 x 1/2 size x 100 mm ~	6.7	1665 x 408 x 255
BM22A	1200	4 x 1/2 size x 100 mm ~	5.2	705 x 615 x 255
BM23A	1800	6 x 1/2 size x 100 mm ~	7.8	1030 x 615 x 255
BM24A	2700	8 x 1/2 size x 100 mm ~	11.7	1355 x 615 x 255
BM25A	2700	10 x 1/2 size x 100 mm ~	11.7	1680 x 615 x 255
BM26A	2700	12 x 1/2 size x 100 mm ~	11.7	2005 x 615 x 255
REFRIGERATED - PANS & LIDS NOT INCLUDED				
BR22	480	4 x 1/2 size #	2.1	705 x 615 x 255 †
BR23	480	6 x 1/2 size #	2.1	1030 x 615 x 255 †
BR24	500	8 x 1/2 size #	2.2	1355 x 615 x 255 †
BR25	500	10 x 1/2 size #	2.2	1680 x 615 x 255 †
BR26	500	12 x 1/2 size #	2.2	2005 x 615 x 255 †

~Pans and lids included. #Pans and lids not included. †Height dimensions exclude motor cage.

Note: Maximum pan depth 100 mm on all hot models and 65 mm on all refrigerated models. The BM series is also available without pans, delete "A" from the Model No.

Roband bain maries are designed to accommodate pans available from Roband Australia. Although other brands of pans may fit, this is not guaranteed due to variations in other manufacturers' pans.

## Straight Glass Hot Food Display Bars

The straight glass hot food display bars have streamlined styling that will enhance food presentation whilst keeping the food at the correct serving temperature. A wide range of sizes and options are available to cater for numerous combinations of gastronorm pans up to 100 mm deep. Set of 1/2 size 65 mm pans & lids included.



### FEATURES

- Stainless steel construction with tubular frame
- Overhead heating and illumination by stylish heat lamps manufactured from extruded aluminium, specifically designed to breathe
- Dura-life stainless steel elements for prolonged element life
- Energy regulator control
- Wet or dry operation^
- Safety lock ball valve drain
- Streamlined for easy cleaning
- Removable cross bars
- Thermometer



E14 (single row)



E24 (double row) with various sizes of pans

^ Machines should not be left unattended. See pages 50 - 52 for all optional accessories.

### SPECIFICATIONS

MODEL	POWER Watts	NO. OF PANS	CURRENT Amps	DIMENSIONS w x d x h (mm)
<b>SINGLE ROW</b>				
E14 / E14RD	2150	4	9.4	1135 x 420 x 675
E16 / E16RD	2300	6	10.0	1665 x 420 x 675
<b>DOUBLE ROW</b>				
E22 / E22RD	1450	4	6.3	705 x 615 x 675
E23 / E23RD	2300	6	10.0	1030 x 615 x 675
E24 / E24RD	3200	8	13.9	1355 x 615 x 675
E25 / E25RD	3450	10	15.0	1680 x 615 x 675
E26 / E26RD	3450	12	15.0	2005 x 615 x 675

Safety lock ball valve drain



Temperature gauge

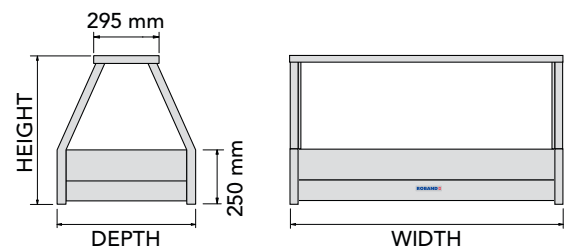

Note: RD signifies roller doors included. Sneeze guards cannot be fitted to the control panel side of single row Food bars when roller doors are installed.  
 Note: Hot food display bars are suitable for short-term food display. They are not a suitable substitute for a chicken humidifier.

They are also designed to accommodate pans available from Roband Australia. Although other brands of pans may fit, this is not guaranteed due to variations in other manufacturers' pans. Hot food display bars are designed to be served around and not over. If units are to be used in a serve over capacity, protection from hot surfaces will need to be considered. Environmental influences will affect the operating performance of hot food displays. Consideration should be given to food types, air movement and ambient temperatures before specifying. For dry, fried foods, Roller Doors are highly recommended.

## Straight Glass Refrigerated Display Bars

These units match the range of "E" series hot food display bars and together they offer the combination of displaying hot and cold foods with uniform, modern appearance. They are designed to take a variety of gastronorm pans up to 65 mm deep. All units combine the use of cold plate and cross fin coil cooling. Set of 1/2 size 65 mm pans & lids included.



### FEATURES

- All stainless steel construction with tubular frame
- Refrigerated cold plate and cross fin coil technology
- ERX models feature a quality refrigeration unit running on environmentally friendly R404A refrigerant
- Overhead fluorescent light
- Quiet operation
- Safety lock ball valve drain
- Streamlined for easy cleaning
- Adjustable digital thermostat with temperature readout
- Removable cross bars
- Rear roller doors fitted as standard

See pages 50 - 52 for all optional accessories.



ERX23RD with various sizes of pans

### SPECIFICATIONS

MODEL	NO. OF PANS	POWER Watts <sup>^</sup>	CURRENT Amps	DIMENSIONS w x d x h (mm)
REFRIGERATED COLD PLATE & CROSS FIN COIL				
ERX23RD	6	530	2.3	1030 x 615 x 675
ERX24RD	8	625	2.7	1355 x 615 x 675
ERX25RD	10	815	3.5	1680 x 615 x 675
ERX26RD	12	815	3.5	2005 x 615 x 675
COLD PLATE & CROSS FIN COIL - PIPED & FOAMED ONLY (NO MOTOR)				
EFX23RD	6	30	0.2	1030 x 615 x 675
EFX24RD	8	45	0.3	1355 x 615 x 675
EFX25RD	10	45	0.3	1680 x 615 x 675
EFX26RD	12	45	0.3	2005 x 615 x 675

<sup>^</sup>Nominal ref. capacity.

Note: RD signifies roller doors included. EFX units are piped and foamed for remote installation and include control panel, thermometer & light. Refrigeration unit and cage is not included for EFX range.

Roband food display bars are designed to accommodate pans available from Roband Australia. Although other brands of pans may fit, this is not guaranteed due to variations in other manufacturers' pans.

Adjustable digital thermostat, 0 °C to 8 °C

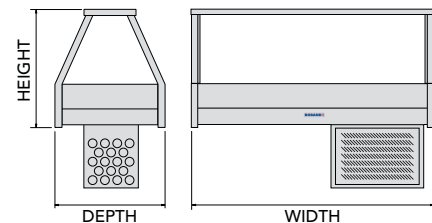
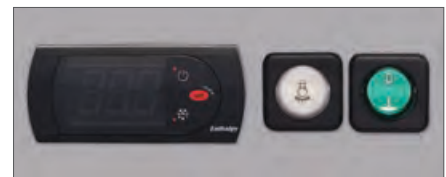

Note: For ERX model range overall height dimensions, add height of motor cage (450 mm).

## Curved Glass Hot Food Display Bars



The curved glass hot food display bar design allows full visual display of your presentations while maintaining the correct serving temperature.

A wide range of sizes and options are available to cater for numerous combinations of gastronorm pans up to 100 mm deep. Set of 1/2 size 65 mm pans & lids included.

### FEATURES

- Stainless steel construction with tubular frame
- Overhead heating and illumination by stylish heat lamps manufactured from extruded aluminium, specifically designed to breathe
- Energy regulator control
- Wet or dry operation^
- Double skin tank for lower running costs
- Dura-life stainless steel elements for prolonged element life
- Safety lock ball valve drain
- Toughened safety glass front
- Streamlined for easy cleaning
- Removable cross bars
- Thermometer

^ Machines should not be left unattended.

See pages 50 - 52 for all optional accessories.



C24

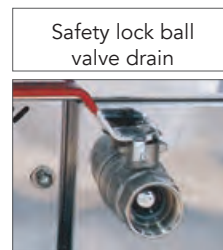

Safety lock ball valve drain

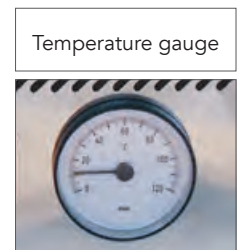

Temperature gauge

### SPECIFICATIONS

MODEL	POWER Watts	NO. OF PANS	CURRENT Amps	DIMENSIONS w x d x h (mm)
DOUBLE ROW				
C22 / C22RD	1450	4	6.3	700 x 615 x 750
C23 / C23RD	2300	6	10.0	1030 x 615 x 750
C24 / C24RD	3200	8	13.9	1355 x 615 x 750
C25 / C25RD	3450	10	15.0	1680 x 615 x 750

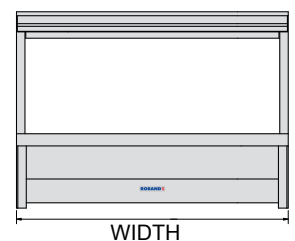
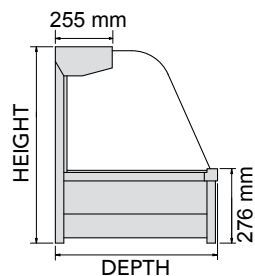

Note: RD signifies roller doors included. Sneeze guards cannot be fitted to the vertical control panel side when roller doors installed.

Note: Hot food display bars are suitable for short term food display. They are not a suitable substitute for a chicken humidifier. They are also designed to accommodate pans available from Roband Australia. Although other brands of pans may fit, this is not guaranteed due to variations in other manufacturers' pans. Hot food display bars are designed to be served around and not over. If units are to be used in a serve over capacity, protection from hot surfaces will need to be considered. Environmental influences will affect the operating performance of hot food displays. Consideration should be given to food types, air movement and ambient temperatures before specifying. For dry, fried foods, Roller Doors are highly recommended.

# Curved Glass Refrigerated Display Bars

These units match the complete range of curved glass hot food display bars. Together they offer a stylish visual display to enhance your product. Designed to take a variety of gastronomic pans up to 65 mm deep. All units combine the use of cold plate and cross fin coil cooling. Set of 1/2 size 65 mm pans & lids included.



## FEATURES

- All stainless steel construction with tubular frame
- Refrigerated cold plate and cross fin coil technology
- Quality refrigeration unit running on environmentally friendly R404A refrigerant
- Overhead fluorescent light
- Quiet operation
- Double skin construction
- Safety lock ball valve drain
- Streamlined for easy cleaning
- Toughened safety glass front
- Adjustable digital thermostat with temperature readout
- Removable cross bars
- Rear roller doors fitted as standard

See pages 50 - 52 for all optional accessories.



CRX24RD

## SPECIFICATIONS

MODEL	NO. OF PANS	POWER Watts <sup>^</sup>	CURRENT Amps	DIMENSIONS w x d x h (mm)
REFRIGERATED COLD PLATE & CROSS FIN COIL				
CRX23RD	6	530	2.3	1030 x 615 x 750
CRX24RD	8	625	2.7	1355 x 615 x 750
CRX25RD	10	815	3.5	1680 x 615 x 750
COLD PLATE & CROSS FIN COIL - PIPED & FOAMED ONLY (NO MOTOR)				
CFX23RD	6	30	0.2	1030 x 615 x 750
CFX24RD	8	45	0.3	1355 x 615 x 750
CFX25RD	10	45	0.3	1680 x 615 x 750

<sup>^</sup>Nominal ref. capacity.

Note: RD signifies roller doors included. CFX units are piped and foamed for remote installation and include control panel, thermometer & light. Refrigeration unit and cage is not included for CFX range.

Roband food display bars are designed to accommodate pans available from Roband Australia. Although other brands of pans may fit, this is not guaranteed due to variations in other manufacturers' pans.

Adjustable digital thermostat, 0 °C to 8 °C

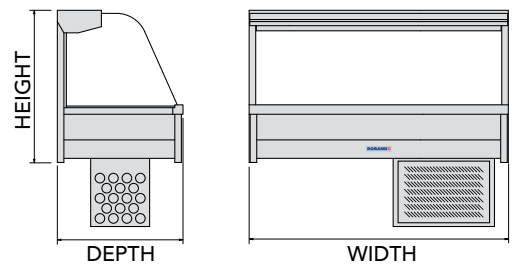
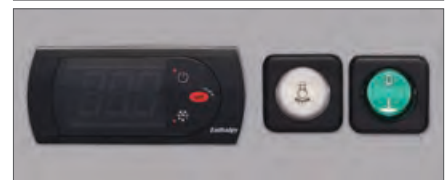

Note: For CRX model range overall height dimensions, add height of motor cage (450 mm).

## Square Glass Hot Food Display Bars



The square glass profile hot food display bars boast the latest in styling and design, at the same time offering all the features and reliability expected of a Roband product. They can be built-in, bench mounted or supplied with a trolley to suit.

A wide range of gastronorm pan sizes available up to 100 mm deep. Set of 1/2 size 65 mm pans & lids included.

### FEATURES

- Stainless steel construction with tubular frame
- Overhead heating and illumination by stylish heat lamps manufactured from extruded aluminium, specifically designed to breathe
- Energy regulator control
- Wet or dry operation^
- Double skin tank for lower running costs
- Dura-life stainless steel elements for prolonged element life
- Safety lock ball valve drain
- Toughened safety glass front
- Streamlined for easy cleaning
- Removable cross bars
- Thermometer

^ Machines should not be left unattended.

See pages 50 - 52 for all optional accessories.



S24

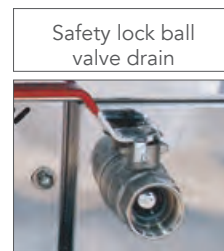

Safety lock ball valve drain

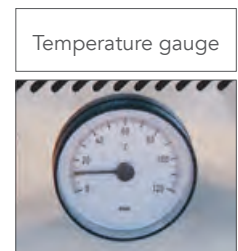

Temperature gauge

### SPECIFICATIONS

MODEL	POWER Watts	NO. OF PANS	CURRENT Amps	DIMENSIONS w x d x h (mm)
DOUBLE ROW				
S22 / S22RD	1450	4	6.3	700 x 615 x 750
S23 / S23RD	2300	6	10.0	1030 x 615 x 750
S24 / S24RD	3200	8	13.9	1355 x 615 x 750
S25 / S25RD	3450	10	15.0	1680 x 615 x 750
S26 / S26RD	3450	12	15.0	2005 x 615 x 750

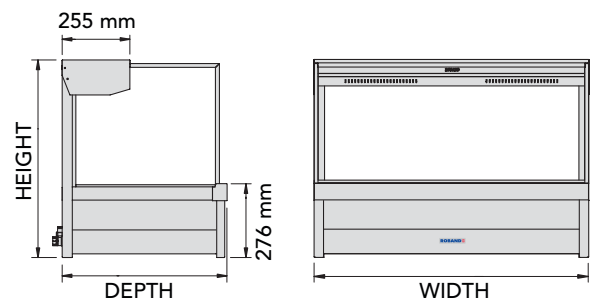

Note: RD signifies roller doors included. Sneeze guards cannot be fitted to the vertical control panel side when roller doors installed.

Note: Hot food display bars are suitable for short term food display. They are not a suitable substitute for a chicken humidifier. They are also designed to accommodate pans available from Roband Australia. Although other brands of pans may fit, this is not guaranteed due to variations in other manufacturers' pans. Hot food display bars are designed to be served around and not over. If units are to be used in a serve over capacity, protection from hot surfaces will need to be considered. Environmental influences will affect the operating performance of hot food displays. Consideration should be given to food types, air movement and ambient temperatures before specifying. For dry, fried foods, Roller Doors are highly recommended.



# Square Glass Refrigerated Display Bars

These units match the complete range of square glass hot food display bars. Together they offer a stylish visual display to enhance your product. Max pan depth 65 mm. All units combine the use of cold plate and cross fin coil cooling. Set of 1/2 size 65 mm pans & lids included.



SRX25RD pictured

## FEATURES

- All stainless steel construction with tubular frame
- Refrigerated cold plate and cross fin coil technology
- Quality refrigeration unit running on environmentally friendly R404A refrigerant
- Overhead fluorescent light
- Quiet operation
- Double skin construction
- Safety lock ball valve drain
- Streamlined for easy cleaning
- Toughened safety glass front
- Adjustable digital thermostat with temperature readout
- Removable cross bars
- Rear roller doors fitted as standard

See pages 50 - 52 for all optional accessories.



## SPECIFICATIONS

MODEL	NO. OF PANS	POWER Watts <sup>^</sup>	CURRENT Amps	DIMENSIONS w x d x h (mm)
REFRIGERATED COLD PLATE & CROSS FIN COIL				
SRX23RD	6	530	2.3	1030 x 615 x 750
SRX24RD	8	625	2.7	1355 x 615 x 750
SRX25RD	10	815	3.5	1680 x 615 x 750
SRX26RD	12	815	3.5	2005 x 615 x 750
COLD PLATE & CROSS FIN COIL - PIPED & FOAMED ONLY (NO MOTOR)				
SFX23RD	6	30	0.2	1030 x 615 x 750
SFX24RD	8	45	0.3	1355 x 615 x 750
SFX25RD	10	45	0.3	1680 x 615 x 750
SFX26RD	12	45	0.3	2005 x 615 x 750

<sup>^</sup>Nominal ref. capacity.

Note: RD signifies roller doors included. SFX units are piped and foamed for remote installation and include control panel, thermometer & light. Refrigeration unit and cage is not included for SFX range.

Roband food display bars are designed to accommodate pans available from Roband Australia. Although other brands of pans may fit, this is not guaranteed due to variations in other manufacturers' pans.

Adjustable digital thermostat, 0 °C to 8 °C

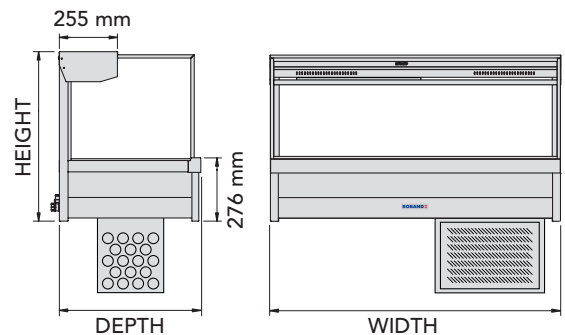
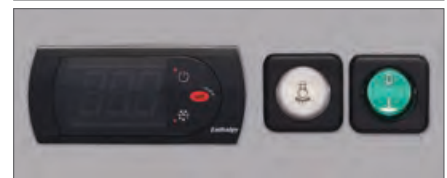

Note: For SRX model range overall height dimensions, add height of motor cage (450 mm).

## Food Bar and Bain Marie Accessories

### Sneeze Guards

A must for self service areas, sneeze guards help prevent food contamination without detracting from the aesthetics of any food displayed. Small sneeze guards are available to suit control panel side of square and curved food display bars and single row straight food display bars. Note: Sneeze guards cannot be fitted to the rear control side of these machines when roller doors are installed.

Larger sneeze guards to suit front panel of single row straight "E" series food display bars or either side of double row straight "E" series food display bars. They can be fitted on the angled face of "E" series machines with or without roller doors.

### Tray Races

Suited to all "E", "C" & "S" series food display bars, tray races provide an ideal serving counter or food preparation area. Made from high quality stainless steel at a depth of 207 mm these units are supplied loose to be affixed on site at the desired height. Models TR14, 16, 22, 23, 24, 25 and 26.

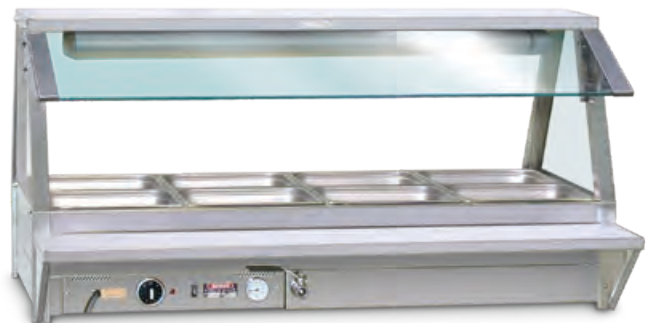

E24 pictured with E-SNZ24 sneeze guard and TR24 tray race

### Chicken Trays

Sized to drop into double row food display bars and utilising all stainless steel construction these trays provide the ideal method to display cooked chickens. With a removable perforated insert these trays present no difficulties in cleaning and will ensure chickens stay hot and moist without pooling of oil.

Combinations of trays will cover the entire range of food display bars. Models ECT22 (535 x 625 mm) and ECT23 (535 x 950 mm).



ECT23 chicken tray

### Stainless Steel Midshelves

Featuring robust stainless steel construction, Roband midshelves are designed to suit double row Food bars, with 3 sizes available. The midshelves provide additional storage space for items which don't need to be kept at a specific temperature like condiments, salt & pepper, take-away containers and more. The midshelf design provides a raised bar on one length of the shelf to avoid items falling off the shelf.

MODEL	To suit	DIMENSIONS w x d x h (mm)
SM22	2 x 2 pan Food bars	653 x 226 x 220
SM23	2 x 3 pan Food bars	978 x 226 x 220
SM24	2 x 4 pan Food bars	1303 x 226 x 220



SM23

## Food Bar / Bain Marie Trolleys

Designed to suit double row units these trolleys are solidly constructed, easy to assemble and include four castors for mobility. Two castors include brakes to ensure safe and sturdy functionality. All units include under-shelf. Supplied flat-packed for self-assembly. Models ET22, 23, 24, 25 and 26 suit double row "E", "C" & "S" series food display bars. Also suits models BM22-BM26 & BR22-BR26 bain maries.

## Trolley Panels

High quality stainless steel panels are available to suit each trolley size, improving the aesthetics and functionality of any given display application. Panels enclose the front and both ends of the corresponding sized trolley. Models ETP22, 23, 24, 25 and 26.



ET25 trolley pictured, with ETP25 panels

## Single & Double Hob

An absolute must for serving soups, these hobs enable the fitting of 7.25 L round pots to BM1, BM2 and BM4 bain maries. Made from high quality stainless steel these simple additions make counterline bain maries even more versatile. Models BMH1 & BMH2.



BMH1 & BMH2

## Insert Hob

Raised in profile this hob allows the fitting of a 7.25 L round pot into our range of hot food display bars and bain maries. Care needs to be taken to check where the raised pot fits into units with angled or curved glass. Model BMH3.

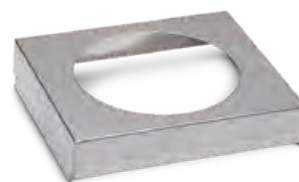

BMH3

## Cross Bars

Available in two lengths these cross bars will provide support to combinations of smaller sized pans. With stainless steel construction and ease of removal for cleaning these additions will expand the functionality of any food display bar. Models ECB1 (short - 30 cm) and ECB2 (long - 51 cm).



ECB1 & ECB2

## Food Bar and Bain Marie Accessories cont'd

### Food Bar / Bain Marie Pan Layout Guide

The Pan Layout Guide can be used to help plan what combinations of pans and cross bars are possible with Roband Food bars and Bain Maries.

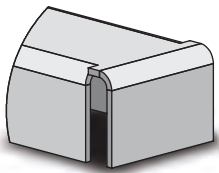
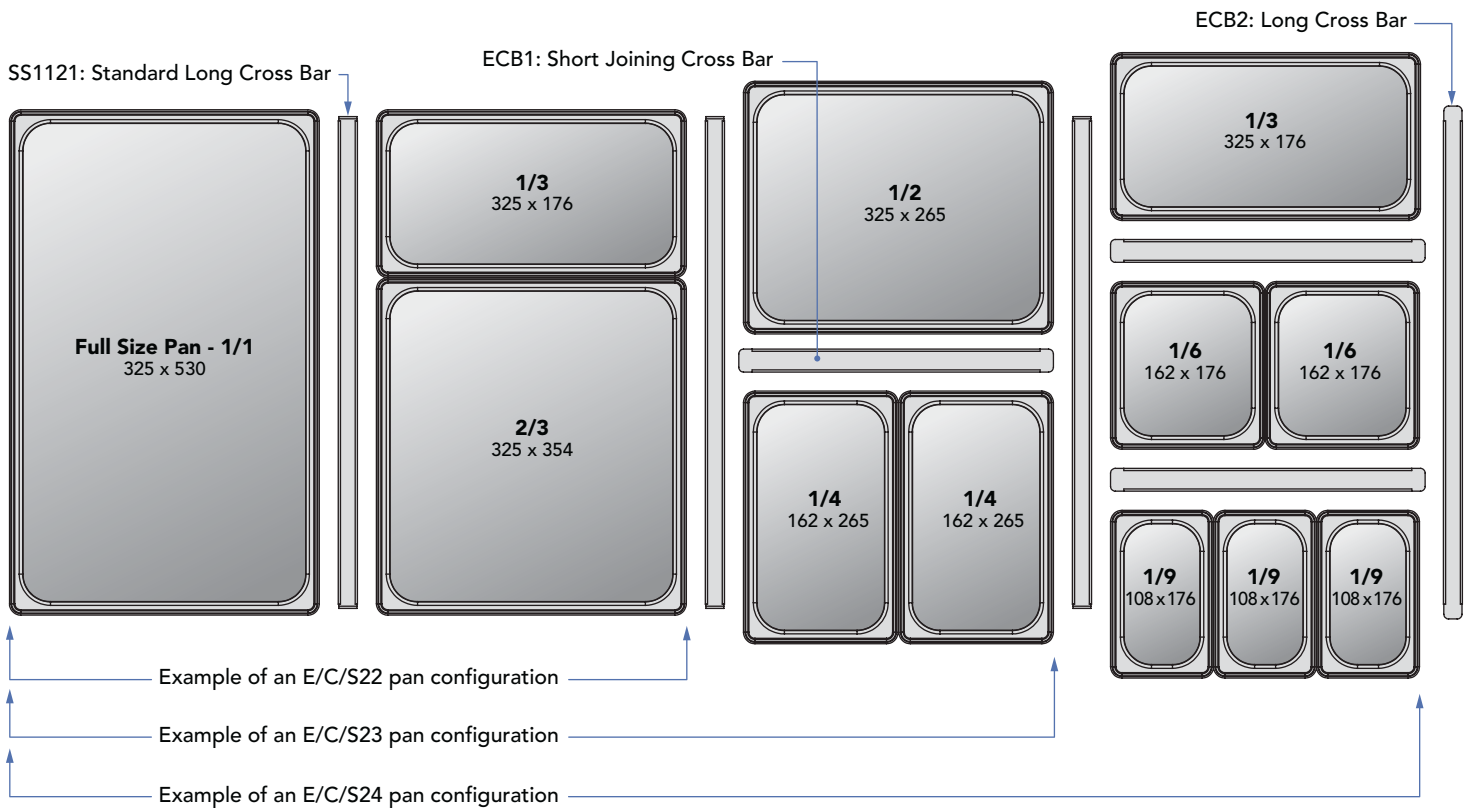

SS1121: This cross bar can only be inserted into the slots in double row tanks

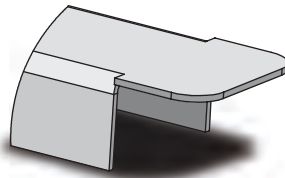

ECB1 and ECB2: These cross bars can be used in any position to allow pans to be supported

### INFORMATION

- The drawing shows a double row module configuration
- When dividing up modules, ensure that each pan is supported on a minimum of two opposite sides. Use cross bars and tank sides to achieve the recommended support. ECB1 and ECB2 are available for this purpose.
- Use ECB1 and ECB2 to divide modules up into smaller sizes to accommodate varying pan combinations.
- The standard cross bar shown (SS1121) is supplied with all double row units. It is not normally necessary to purchase additional quantities of these parts.



E24 pictured with various pans



# Modular Heat Lamp

## Helping you to keep takeaway food safer & warmer/hotter for longer!

The HL350 is a compact modular designed heat lamp manufactured from stainless steel, incorporating an easy fit 230 volt, 350 watt globe. The easy fit globes feature a protective quartz glass outer layer that encapsulates the inner globe allowing for safe handling. It is designed for use in custom fabricated installations as a modular component to be wired in parallel.



## SPECIFICATIONS

MODEL	DESCRIPTION	VOLTS	POWER Watts
COMPLETE WITH 300 MM PTFE FLYING LEADS (A + N) FOR INSTALLATION			
HL350	Modular lamp, single globe	230	350

## DIMENSIONS

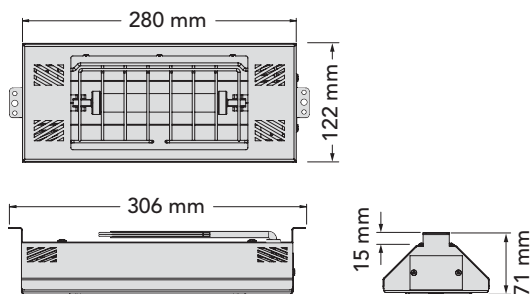

HL350

Mounting bracket each end

# Individual Heat Lamps

These units are effective for overhead heating in food preparation and serving areas. Designed specifically to be wired in pairs and in series, Roband heat lamps maintain prepared food at the correct serving temperature, while enhancing presentation at the same time.

## SPECIFICATIONS

	MODEL	DESCRIPTION	POWER Watts*	CURRENT Amps	DIMENSIONS w x d x h (mm)
A	HL22 <sup>†</sup>	500 W lamp only	250 <sup>†</sup>	1.1	190 x 120 x 50
	HL24 <sup>†</sup>	1000 W lamp only	500 <sup>†</sup>	2.2	270 x 120 x 50
	HL26 <sup>†</sup>	1500 W lamp only	750 <sup>†</sup>	3.3	335 x 120 x 50
B	HL22C <sup>†</sup>	HL22 with cover	250 <sup>†</sup>	1.1	270 x 120 x 80
	HL24C <sup>†</sup>	HL24 with cover	500 <sup>†</sup>	2.2	270 x 120 x 80
	HL26C <sup>†</sup>	HL26 with cover	750 <sup>†</sup>	3.3	335 x 120 x 80
C	HLC190	Cover to suit HL22	N/A	N/A	270 x 120 x 55
	HLC260	Cover to suit HL24	N/A	N/A	270 x 120 x 55
	HLC330	Cover to suit HL26	N/A	N/A	335 x 120 x 55

<sup>†</sup>Must be installed in pairs and wired in series. \*Total power output of 1 pair wired in series.

## FEATURES

- Stainless steel construction
- Long life globes
- Series wiring further extends globe life
- Easily replaceable globes
- Aesthetic cover design



HL26 x 2 pictured



A

HL26C x 2 pictured



B

HLC330 x 2 pictured



C

## Quartz Heat Lamp Assemblies



The stylish and functional Roband quartz heat lamp assemblies provide a balance of heat and light to front or back of house applications. They are manufactured from extruded anodised aluminium, with a number of different sizes and options available to suit various requirements. All models come with a standard mount bracket. Optional mount kit is also available. See page 58 for details.

Designed by Roband Australia, Easy Fit Globes feature a protective quartz outer layer that encapsulates the inner globe allowing for easier handling. This secondary layer of glass also protects food from globe breakages by capturing the shards and eliminating the need for a traditional glass window in the base of the cover. *Lamp replacement can now be performed without the need for an electrician and takes only seconds.*

### Standard Models

The standard heat lamp assemblies (e.g. HQ450E) come **with** a control box that houses the isolating on/off switch. They also feature a simple mounting system and come complete with a 10 Amp plug and cord.

### Fabricator Models

The heat lamp assemblies are also available **without** the control box and on/off switch (e.g. HUQ375E) so they can be connected to a remote switch setup. The removal of the control box shortens the length of the lamp assembly accordingly.

Standard mounting bracket available on standard and fabricator models





## SPECIFICATIONS - STANDARD MODELS (INCLUDES CONTROL BOX)

MODEL	INTERNAL LAMPS	MOUNT TYPE	CURRENT Amps	POWER Watts	LENGTH mm	LAMP CENTRES*	INCLUSIONS
HQ450E	1 lamp	Standard	1.5	350	450	N/A	Switch, plug & cord
HQ900E	2 lamps	Standard	3.0	700	900	400	Switch, plug & cord
HQ1200E	3 lamps	Standard	4.6	1050	1200	345	Switch, plug & cord
HQ1500E	4 lamps	Standard	6.1	1400	1500	345	Switch, plug & cord
HQ1800E	4 lamps	Standard	6.1	1400	1800	400	Switch, plug & cord
HQ2100E	5 lamps	Standard	7.6	1750	2100	400	Switch, plug & cord

\*Length between centre of each lamp.



HQ1200E

## SPECIFICATIONS - FABRICATOR MODELS (NO CONTROL BOX)

MODEL	INTERNAL LAMPS	MOUNT TYPE	CURRENT Amps	POWER Watts	LENGTH mm	LAMP CENTRES*	INCLUSIONS
COMPLETE WITH A, N & E WIRE IN PTFE 1700 MM LENGTH FOR INSTALLATION TO YOUR OWN CONTROLLER							
HUQ375E	1 lamp	Standard	1.5	350	375	N/A	N/A
HUQ825E	2 lamps	Standard	3.0	700	825	400	N/A
HUQ1125E	3 lamps	Standard	4.6	1050	1125	345	N/A
HUQ1425E	4 lamps	Standard	6.1	1400	1425	345	N/A
HUQ1725E	4 lamps	Standard	6.1	1400	1725	400	N/A
HUQ2025E	5 lamps	Standard	7.6	1750	2025	400	N/A

\*Length between centre of each lamp.



HUQ1125E

Showing wire guard open for easy replacement of the globe



Dimensions for all standard quartz and fabricator quartz lamps (HQ & HUQ models). Brackets are removable.

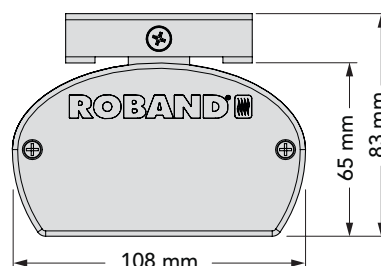

## Infra-Red Heating Assemblies



Roband infra-red heating assemblies are manufactured from an extruded anodized aluminium section, specifically designed to breathe. *These units are designed for use at either front or back of house where more heat and no light is required.* The heat is provided by a stainless steel element and an energy regulator is used on the standard units to precisely control the output, emitting a very even heat over the length of the warming area. All models come with a standard mount bracket. Optional mount kit is also available. See page 58 for details.

### Standard Models

The standard infra-red heating assemblies (e.g. HE900) come **with** a control box that houses the isolating on/off switch and an energy regulator to control heat output. They also feature a simple mounting system and come complete with a 10 Amp plug and cord.

### Fabricator Models

The infra-red heating assemblies are also available **without** the control box, energy regulator and on/off switch (e.g. HUE825) so they can be connected to a remote switch setup. The removal of the control box shortens the length of the assembly accordingly.

Standard mounting bracket available on standard and fabricator models



A variable control energy regulator is used to precisely control the output







## SPECIFICATIONS - STANDARD MODELS (INCLUDES CONTROL BOX)

MODEL	DESCRIPTION	MOUNT TYPE	CURRENT Amps	POWER Watts	LENGTH mm	INCLUSIONS
HE900	1 element	Standard	3.9	900	900	Switch, plug & cord
HE1200	1 element	Standard	5.2	1200	1200	Switch, plug & cord
HE1500	1 element	Standard	6.5	1500	1500	Switch, plug & cord
HE1800	1 element	Standard	7.8	1800	1800	Switch, plug & cord



HE1200

## SPECIFICATIONS - FABRICATOR MODELS (NO CONTROL BOX)

MODEL	DESCRIPTION	MOUNT TYPE	CURRENT Amps	POWER Watts	LENGTH mm	INCLUSIONS
COMPLETE WITH A, N & E WIRE IN PTFE 1700 MM LENGTH FOR INSTALLATION TO YOUR OWN CONTROLLER						
HUE825	1 element	Standard	3.9	900	825	N/A
HUE1125	1 element	Standard	5.2	1200	1125	N/A
HUE1425	1 element	Standard	6.5	1500	1425	N/A
HUE1725	1 element	Standard	7.8	1800	1725	N/A



HUE1125

Dimensions for standard infra-red heating assemblies (HE models). Brackets are removable.

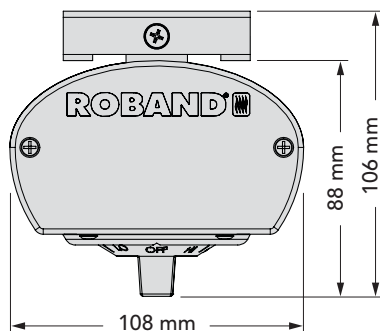

Dimensions for fabricator infra-red heating assemblies (HUE models). Brackets are removable.

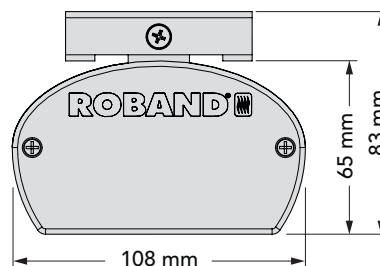

## Fluorescent Lighting Assemblies

Roband fluorescent lamp assembly profiles match the aluminium extrusion from which the quartz lamp assemblies are manufactured.

Specifically designed for use in refrigerated displays or *where illumination is required without heat*, these units have a diffused perspex cover over the light. They also feature a simple mounting system and come complete with an isolating switch and a 10 Amp plug and cord.

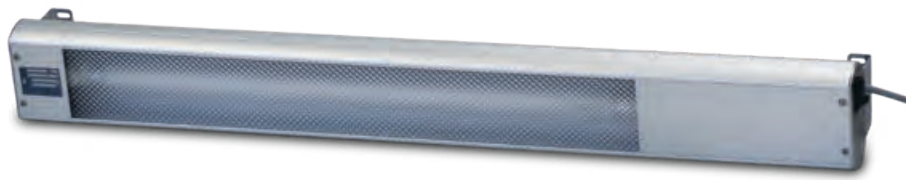

HF900

### SPECIFICATIONS

MODEL	DESCRIPTION	POWER Watts	CURRENT Amps	LENGTH mm
HF900	1 fluorescent globe	30	0.1	900
HF1500	1 fluorescent globe	45	0.2	1500

Dimensions for all fluorescent lighting assemblies (HF models). Brackets are removable.

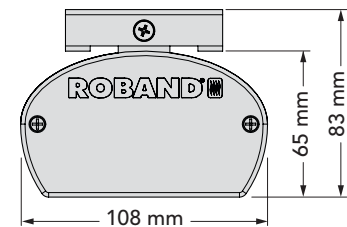

## Optional Mount Kit

Mount kit for Quartz, Infra-red series & Fluorescent assemblies. The kit includes 2 x 19 mm diameter round tubes, inserts and mounting brackets, with instructions for installation by an electrician. 600 mm tubes can be cut to the desired length.



HM600

### SPECIFICATIONS

MODEL	DESCRIPTION	MOUNT TYPE	LENGTH (mm)
HM600	Mount kit for all Quartz lamps, Infra-red heat assemblies & Fluorescent assemblies.	Round	600



Fabricator model with HM600 mount kit installed and shortened to the desired length



# Heat Lamp Stands



Available in two sizes, the portable Roband Heat Lamp Stands are designed to hold Roband Quartz Lamp or Infra-red Heating Assemblies *at an ideal height above the bench.*

## FEATURES

- Two sizes available to suit 900 & 1200 mm length Roband Heat or Illumination Assemblies
- Robust stainless steel construction
- Adjustable feet to level on uneven surfaces
- Stylish industrial design
- Quartz and Infra-red Assemblies sold separately
- Lamps positioned 350 mm above the base

HLS935



HLS1235



## SPECIFICATIONS

STAND MODEL	DIMENSIONS w x d x h (mm)	WEIGHT Kg
HLS935	1040 x 352 x 437 mm	5
HLS1235	1340 x 352 x 437 mm	6

SUITS QUARTZ & INFRA-RED ASSEMBLY MODELS*	DIMENSIONS Length (mm)	POWER Watts	CURRENT Amps
HQ900E	900	700	3
HE900	900	900	3.9
HQ1200E	1200	1050	4.6
HE1200	1200	1200	5.2

\*Sold separately.

# Double Skinned Hot Water Urns

Robatherm Hot Water Urns are stylishly finished and designed for commercial use. The Urns feature a unique mode selector switch that allows either variable or pre-set temperature control, providing ultimate flexibility and ease of use.

With the mode set to variable, the temperature can be controlled across a wide range via the graduated knob. Variable mode will suit those users who require warm or boiling water for their special application.

Switching the mode selector to pre-set will fix the temperature at 95 °C, the optimal temperature for most applications involving tea and coffee. Using pre-set mode offers a fast and easy setup, achieving consistent temperatures every time. Adjustment of the knob in pre-set mode has no effect on the temperature setting of the urn - it remains constant at nominal 95 °C. This prevents continuous boiling and excessive consumption of energy.



UDS10VP



UDS20VP

## FEATURES

- Mode selector switch for either variable or pre-set 95 °C temperature control
- Available in 10, 20 or 30 litre sizes
- Double skinned tank construction for safe side temperatures, less than 50 °C
- Long life concealed elements allowing easy cleaning inside the urn
- Stylish brushed finish stainless steel exterior
- High grade 304 stainless steel inner tank
- Sturdy stainless steel non-drip tap
- Twist-lock lid with steam vent
- Sight-glass with cup capacity graduations
- Boil dry protection
- Optional accessory, HF1 Hands-free Tap Lever

Double skin tank with concealed element



UDS10VP Urn shown with optional accessory HF1 Hands-free Tap Lever



Variable or pre-set temperature functionality



## SPECIFICATIONS

MODEL	CAPACITY* Cups (160 ml)	POWER Watts	CURRENT Amps	DIMENSIONS dia. x h (mm)
UDS10VP	50	2300	10.0	240 x 480
UDS20VP	120	2300	10.0	330 x 550
UDS30VP	160	2300	10.0	330 x 645

\*Approximate capacity.

# Percolator

The Robatherm Percolator, arguably best in its class, has been cleverly designed to deliver outstanding percolated coffee or tea in a simple to use fashion and with minimal parts to clean. Whilst the taste of the finished beverage speaks for itself, it's the elegant style, double skin construction with quality components such as a stainless steel tap, twist lock lid and sturdy handles coupled with the simple and effective coffee/tea basket design that sets this percolator apart from the competition.



## FEATURES

- Double skin construction – reducing external touch temperatures
- Simplified and effective basket ensuring minimal parts to clean and preventing coffee granules or tea leaves from entering drink to be served
- Patented “safety dome” ensures a great tasting beverage and reduces risk of scalding if lid is inadvertently removed during percolation cycle
- Simple on/off operation – separate percolator element delivers coffee or tea whilst warming element keeps the beverage at serving temperature during and after percolation cycle
- Sturdy high-quality non-drip stainless steel tap
- 12.8 litre, 80 (160 ml) cup approximate capacity
- Twist lock lid with quality handles
- Optional accessory, HF1 Hands-free Tap Lever

## SPECIFICATIONS

MODEL	CAPACITY* Litres / Cups (160 ml)	POWER Watts	CURRENT Amps	DIMENSIONS dia. x h (mm)
CP80	12.8 / 80	1650	7.2	270 x 500

\*Approximate capacity.

The patented “safety dome” ensures great tasting coffee while also reducing the scalding risk.



UDS10VP Urn shown with optional accessory HF1 Hands-free Tap Lever



CP80

## Operating Specifications and Disclaimers

### Operating Specifications and Disclaimers

**Dimensions** detailed in this brochure are nominal only and may vary within tolerances from machine to machine.

**Alterations to machine specifications** may occur at any time due to ongoing research and development. Please check details with our offices for the latest information and specifications.

**Performance specification** evaluations are carried out under test conditions of either 230V per phase or 50Hz. All standard Roband, Austheat and Robatherm products are designed to run at 230V single phase, 50Hz. Equipment to suit other voltages can typically be manufactured to order. Variations to indicative machine performance may occur as a result of variances in the voltage delivered to an installed unit. Lower voltages will result in significant reductions in performance, particularly in radiant-heat toasters (conveyor toasters, griller toasters etc.). Should you have any concerns in this regard, please contact our office and one of our technicians will discuss the issue with you.



### Precautionary note

We recommend that only demineralised water be used with our products, for both cleaning and (if applicable) operational purposes. Water with high mineral content (also referred to as “hard water”) may lead to corrosion of the stainless steel surfaces over time. The durability and longevity of other components may also be adversely affected by water with a high mineral content.

Additionally we counsel against the use of spray applicators, chemical cleaners and water jets in the cleaning of electrical equipment. The use of direct spray applicators can promote moisture ingress inside electrical switches and cause electrical failures. Chemical cleaners with low PH levels, particularly chloride based cleaners can damage stainless steel, aluminium, plastics and polycarbonates and should be avoided to ensure the longevity of any equipment.



## Warranty

Our machines are manufactured to the highest standards and every care is taken to ensure that all completed goods leave our factory in perfect working order and in pristine condition.

All Roband, Austheat and Robatherm machines are backed by a 12 month parts and labour warranty from the date of purchase. Additionally all units come with a comprehensive set of instructions detailing operation, safety and cleaning techniques. These instructions should be read in their entirety prior to operating any machine.

A written warranty also accompanies each machine, however details of the terms and conditions are available at any time on request. Typically, items such as glass, lamps and non-stick coating are excluded, but for full details please contact one of our offices.

The goods come with guarantees that cannot be excluded under the Australian Consumer Law (ACL). You are entitled to a replacement or refund for a major failure and for compensation for any other reasonably foreseeable loss or damage. You are also entitled to have the goods repaired or replaced if they fail to be of acceptable quality and the failure does not constitute a major failure.

Contact details for warranty:

**Phone: 1800 268 848 (within Australia)**

**Email for Warranty: [warranty@roband.com.au](mailto:warranty@roband.com.au)**

## Earth Leakage

Tubular heating elements (as used in most commercial heating equipment) may be subject to moisture absorption which can result in nuisance tripping of RCD's (Safety Switches). Although most cases can be solved easily by contacting our offices for advice, this is nevertheless an inherent characteristic of such elements and is not covered by warranty.

For further information regarding this or any other matter please contact our head office. Contact details can be found on the back cover of this brochure.

## Designed to Perform ~ Built to Last!



**Roband Australia Pty Ltd**  
1 Inman Road,  
Cromer, NSW 2099  
Australia  
Tel: +61 2 9971 1788  
Email: sales@roband.com.au

**Roband (Europe) Ltd**  
Haygarth Park, Blaenau Ffestiniog  
Gwynedd, North Wales  
LL41 3PF, UK  
Tel: +44 (0) 1766 830 456  
Email: info@robandeurope.com

All standard Roband, Austheat and Robatherm products are designed to run at 230V per phase, 50Hz.

All dimensions are nominal only. All information contained in this brochure should serve as a guide only and is subject to change without notice due to constant research and development.

© 2021 Roband Australia Pty. Ltd. ACN 003 049 063 ABN 34 864 327 105

® is a registered trademark of Roband Australia Pty. Ltd.

Catalogue printed February 2022.

Distributor: