

Model:  
**TRCB-52**

**Chef Base:**  
*Drawered Refrigerator*



## TRCB-52

- ▶ True's refrigerated chef bases are designed with enduring quality that protects your long term investment.
- ▶ Designed using the highest quality materials and components to provide the user with colder product temperatures, lower utility costs, exceptional food safety and the best value in today's food service marketplace.
- ▶ Oversized, environmentally friendly (134A) forced-air refrigeration system holds .5°C to 3.3°C.
- ▶ Cabinet top is one piece, heavy duty reinforced stainless steel. Drip resistant "V" edge protects against spills. Supports up to 717 lbs. (326 kg).
- ▶ All stainless steel front, top and sides. Matching aluminum finished back.
- ▶ Each drawer accommodates three (3) 1/1 GN (530mm x 325 mm x 100mm WxDxH) food pans (sold separately).
- ▶ Heavy-duty stainless steel drawer slides and rollers. Removable without tools for easy cleaning.
- ▶ Foamed-in-place using a high density, polyurethane insulation that has zero ozone depletion potential (ODP) and zero global warming potential (GWP).

## PLAN VIEW

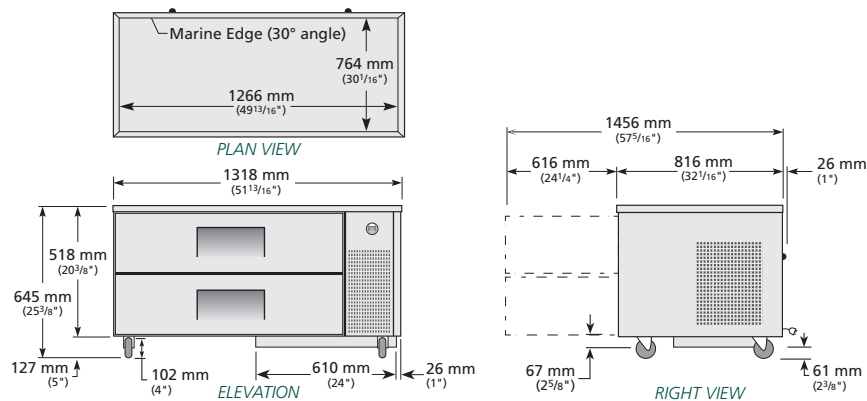

## ROUGH-IN DATA

Voltage: 220-240V/50Hz

Specifications subject to change without notice.  
Chart dimensions rounded up to the next whole millimeter (inches rounded up to the next 1/8").

Model	Drawers	Cabinet Dimensions (mm)			HP	Voltage	Amps	Capacity (litres)	Refrigerant	Crated Weight (kg)
		W	D†	H						
TRCB-52	2	1318	816	645	1/3	230-240/50/1	3.8	280	134A	155

† Depth does not include 26 mm for rear bumpers.