

SPECIFICATION SHEET

MODEL: UC-L Energy

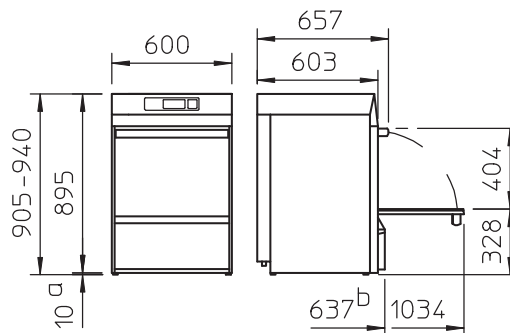

TECHNICAL INFORMATION

Dimensions	600w x 603d x 905-940h
Rack Dimension	500 x 500
Clear Entry Height	404
Rinse Water Consumption	2L Per Cycle

WATER CONNECTIONS

Connection Point	3/4 inch
Inlet Temperature	20c Max
Flow Rate	3 L/Min
Flow Pressure	1.5 - 6 bar

ELECTRICAL

Single Phase (Standard)	240v 1P 50Hz - 15amp (TCL 3.4Kw)
3 Phase (optional)	415v 3P 50Hz - 15 or 20amp (TCL 7.9Kw)

GENERAL DATA

Weight (Net/Gross)	75/85Kg
Tank Capacity	15.3L
Noise Emission	55dB(A)
Cycle Times	120/90/60 Seconds (Adjustable)

STANDARD INCLUSIONS

1x 15amp Plug and Lead
1x 1m Flexible Water Connection Hose
1x 1m Flexible Waste Hose
1x 500 x 500 Flat Rack
1x 500 x 500 Plate Rack

STANDARD FEATURES

- Touch display with glass surface
- Vario power warewashing system for adjustable pressure
- Quadruple filtration system with clouding sensor
- Fully insulated
- Drain pump
- Rinse booster pump
- Integrated chemical dosing with storage tanks for rinse aid and detergent
- Integrated energy heat recovery system