

SPECIFICATION SHEET

MODEL: UC-S

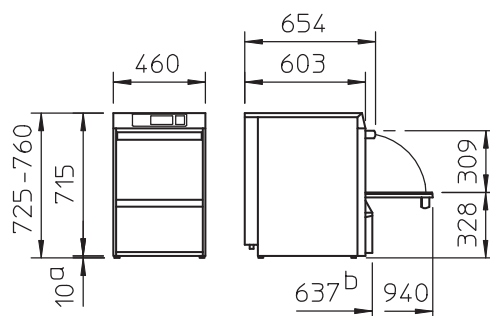

TECHNICAL INFORMATION

Dimensions	460w x 603d x 725-760h
Rack Dimension	400 x 400
Clear Entry Height	309
Rinse Water Consumption	1.8L Per Cycle

WATER CONNECTIONS

Connection Point	3/4 inch (19mm)
Inlet Temperature	60c Max
Flow Rate	4 L/Min
Flow Pressure	1 - 6 bar

ELECTRICAL

Single Phase (Standard)	240v 1P 50Hz - 15amp (TCL 3.2Kw)
3 Phase (Optional)	415v 3P 50Hz - 15 or 20amp (TCL 7.9Kw)

GENERAL DATA

Weight (Net/Gross)	59/68Kg
Tank Capacity	9.5L
Noise Emission	55dB(A)
Cycle Times	120/90/60 Seconds (Adjustable)

STANDARD INCLUSIONS

1x 15amp Plug and Lead
1x 1m Flexible Water Connection Hose
1x 1m Flexible Waste Hose
1x 4 Row Glass Basket - 400 x 400

STANDARD FEATURES

- Touch display with glass surface
- Vario power warewashing system for adjustable pressure
- Quadruple filtration system with clouding sensor
- Fully insulated
- Drain pump
- Rinse booster pump
- Integrated chemical dosing with storage tanks for rinse aid and detergent